

# High Intensity Discharge Lamps

Bulb Identification .....	3-2	Saf-T-Gard® Mercury Lamps.....	3-18
Lamp Locator .....	3-2	E-Z Merc® Self-Ballasted Lamps (Incandescent Retrofit) .....	3-18
Base Identification .....	3-5	<b>Export Lamps</b>	
Introduction .....	3-5	Metal Halide .....	3-18
Product Information.....	3-6	Lucalox® High Pressure Sodium .....	3-18
HID Brand Name Cross Reference.....	3-8	<b>General Information</b> .....	3-19
Section Headings .....	3-8	<b>Operating Notes</b> .....	3-20
<b>ConstantColor® CMH® Metal Halide Lamps</b>		<b>Dimming</b> .....	3-20
CMH® MR16 .....	3-9	<b>Footnotes</b> .....	3-20
CMH® PAR.....	3-9	<b>Warning Notices</b> .....	3-21
CMH® Elliptical.....	3-10	<b>Important Notice</b> .....	3-21
CMH® Elliptical Open-Rated.....	3-10	<b>Warning and Caution Notices</b> .....	3-22
CMH® Single-Ended G12 ULTRA .....	3-10	<b>Cross-Reference</b> .....	3-30
CMH® Single-Ended G12.....	3-10		
CMH® Double-Ended TD.....	3-10		
CMH® GU6.5 .....	3-11		
CMH® Mini ULTRA.....	3-11		
CMH® Mini's .....	3-11		
CMH® Chromafit™ .....	3-11		
High-Watt CMH® SPXX .....	3-11		
<b>PulseArc® Multi-Vapor® Metal Halide Lamps</b> .....	3-11		
<b>Multi-Vapor® Metal Halide Lamps</b> .....	3-12		
<b>High Output and XHO Multi-Vapor® Metal Halide Lamps</b> .....	3-13		
<b>Sports Lighting</b> .....	3-13		
<b>Protected Multi-Vapor® Metal Halide Lamps</b> .....	3-14		
<b>Chromafit™ Multi-Vapor® Metal Halide Lamps (HPS Retrofit Lamps)</b> .....	3-14		
<b>I-Line Multi-Vapor® Metal Halide Lamps (Mercury Retrofit Lamps)</b> .....	3-14		
<b>Saf-T-Gard® Self-Extinguishing Multi-Vapor® Lamps</b> .....	3-15		
<b>Arcstream® Metal Halide Lamps</b> .....	3-15		
<b>Lucalox® High Pressure Sodium Lamps</b> .....	3-15		
<b>Ecolux® High Pressure Sodium Lamps (TCLP Compliant)</b> .....	3-15		
<b>Standby Longlife Lucalox® Lamps</b> .....	3-16		
<b>Ecolux® NC Non-Cycling High Pressure Sodium Lamps (TCLP Compliant)</b> .....	3-17		
<b>Deluxe Lucalox® High Pressure Sodium Lamps</b> .....	3-17		
<b>E-Z® Lux High Pressure Sodium Lamps (Mercury Retrofit)</b> .....	3-17		
<b>Mercury Lamps</b> .....	3-17		

Incandescent

Halogen

High Intensity  
Discharge

Fluorescent

Compact  
Fluorescent

Ballast

LED Lamps  
and Systems

Stage and Studio

Miniature and  
Sealed Beam

Projection

# High Intensity Discharge Lamps

## Bulb Identification

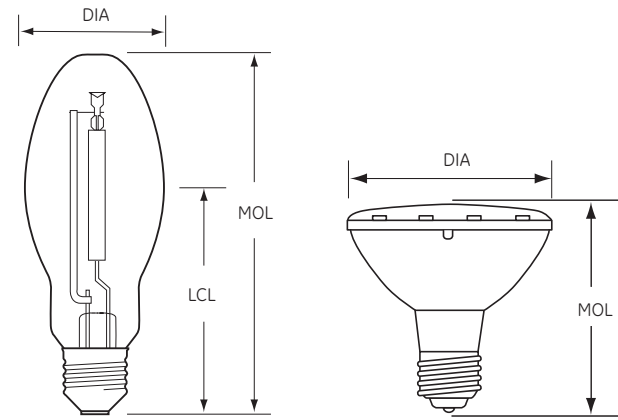

DIA: Diameter of bulb at widest point.  
 MOL: Maximum Overall Length including base or pins.  
 LCL: Distance between the center of the arc tube and the Light Center Length reference plane.  
 Note: Lamp drawings are not drawn to scale. Be sure to check size and dimension information when identifying each lamp.

To convert inches to millimeters, multiply the dimension (in inches) by 25.4 (i.e. 1.5" x 25.4 = 38.1 mm).

## Lamp Locator

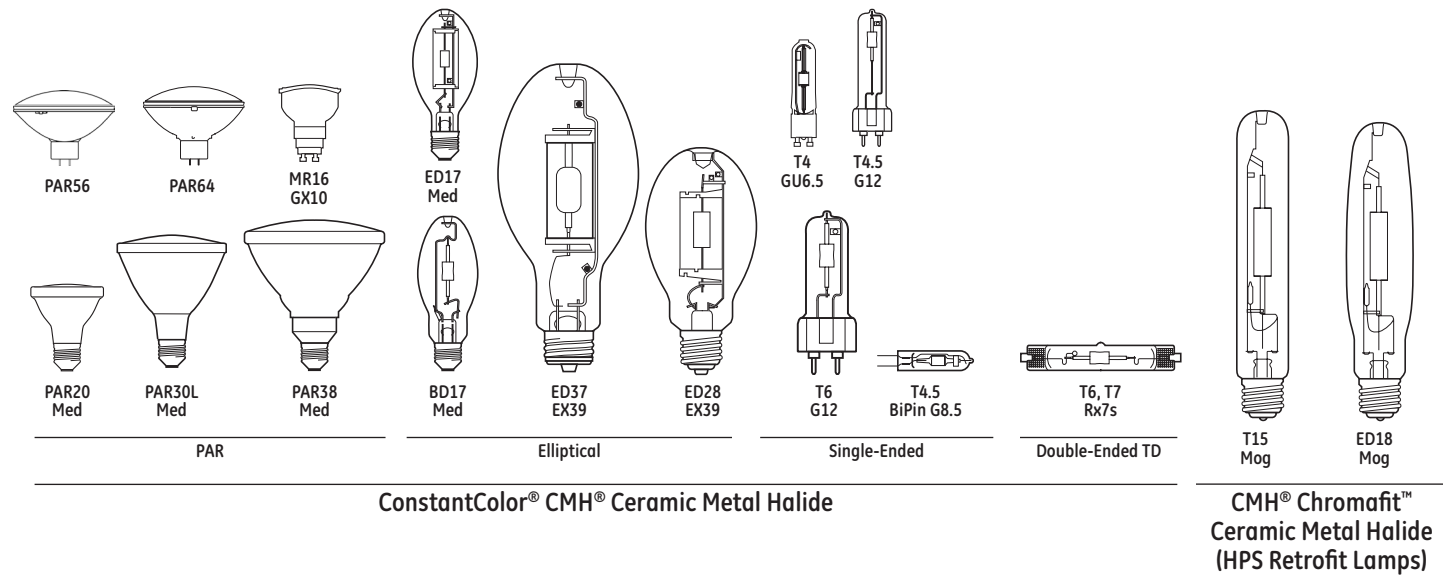

ConstantColor® CMH® Ceramic Metal Halide

CMH® Chromafit™ Ceramic Metal Halide (HPS Retrofit Lamps)

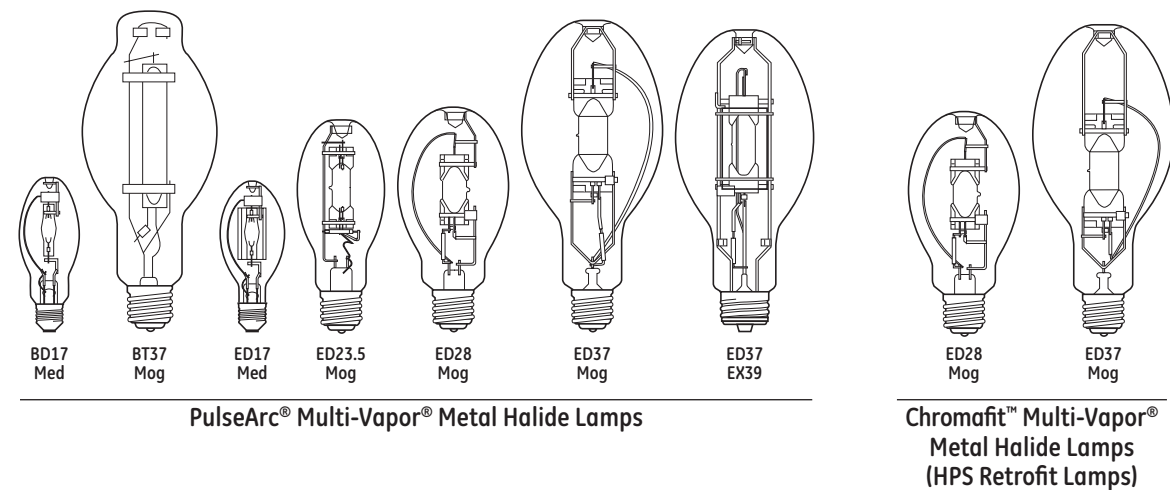

PulseArc® Multi-Vapor® Metal Halide Lamps

Chromafit™ Multi-Vapor® Metal Halide Lamps (HPS Retrofit Lamps)

## Lamp Locator (continued)

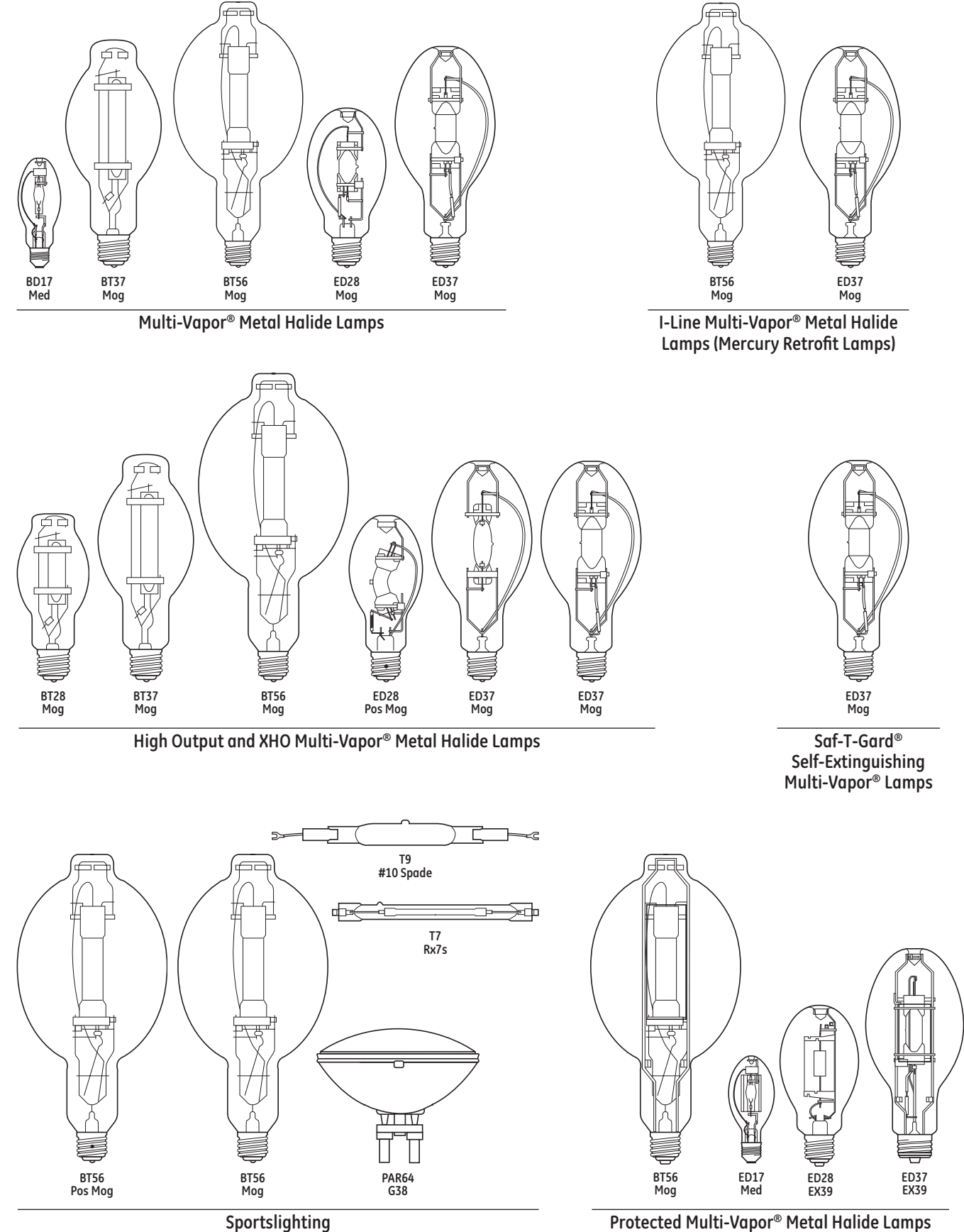

Multi-Vapor® Metal Halide Lamps

I-Line Multi-Vapor® Metal Halide Lamps (Mercury Retrofit Lamps)

High Output and XHO Multi-Vapor® Metal Halide Lamps

Saf-T-Gard® Self-Extinguishing Multi-Vapor® Lamps

Sportslighting

Protected Multi-Vapor® Metal Halide Lamps

Incandescent  
Halogen  
High Intensity Discharge  
Fluorescent  
Compact Fluorescent  
Ballast  
LED Lamps and Systems  
Stage and Studio  
Miniature and Sealed Beam  
Projection

# High Intensity Discharge Lamps

## Lamp Locator (continued)

**Arcstream® Metal Halide Lamps**

- ED18 Mog
- CAP BiPin GY9.5
- T6 R7s
- T7 R7s
- T6 BiPin G12
- T15 Mog

**Ecolux® NC Non-Cycling High Pressure Sodium Lamps (TCLP Compliant)**

- ED18 Mog
- ED23.5 Mog

**Ecolux® High Pressure Sodium Lamps (TCLP Compliant)**

- ED18 Mog
- ED23.5 Mog

**Lucalox® High Pressure Sodium Lamps**

- B17 Med
- ED18 Mog
- ED23.5 Mog
- E25 Mog
- ED28 Mog
- ED37 Mog
- T15 Mog
- T7 Rx7s

**Deluxe Lucalox® High Pressure Sodium Lamps**

- B17 Med
- ED18 Mog
- ED23.5 Mog
- ED28 Mog

**Mercury Lamps**

- A23.5 Med
- B17 Med
- BT37 Mog
- BT56 Mog
- ED23.5 Mog
- ED28 Mog
- ED37 Mog
- R40 Med
- R40 Mog
- R52 Mog
- R60 Mog
- T16 Mog

## Lamp Locator (continued)

**E-Z Lux® High Pressure Sodium Lamps (Mercury Retrofit)**

- BT37 Mog
- ED28 Mog
- ED28 Mog
- ED37 Mog

**Saf-T-Gard® Mercury Lamps**

- BT37 Mog
- ED24 Med
- ED28 Med
- ED28 Mog
- R57 Mog

**E-Z Merc® Self-Ballasted Lamps (Incandescent Retrofit)**

## Base Identification

PG12 (Export Only), Recessed Single Contact R7s, 2-Lug Sleeve BV22d, BiPin G8.5, GU6.5, GX10, Med Screw E26, Export E27, Mog Screw E39, EX39, Position-Oriented Mogul, Export E40, Admedium Skirted, Med Skirt E26/50x39, BiPin GY9.5, BiPin G12, Mogul BiPost G38, Ext. Mog End Pr GX16d

## Introduction

GE HID lamps provide the following benefits:

**High Efficacy/Low Operating Cost.** HID is generally the most efficient light source. Better efficiency almost always means lower operating cost.

**Long Life.** Most HID lamps have life ratings that are better than incandescent lamps and similar to fluorescent lamps.

**Compact Size.** An HID lamp produces high light output from a relatively compact source. Like incandescent, it is a "point" light source, which allows for good optical control.

The chart at right shows how HID lamps compare to incandescent, halogen, and fluorescent in terms of efficiency and rated life. Efficiency is measured in lumens per watt (LPW). Rated life for most lamp types is the number of burning hours when 50% of the tested samples have failed and 50% are still operational. For both HID and fluorescent, lamp life depends on the number of hours per start. The combination of high efficiency and long life makes HID an ideal light source for many commercial and industrial applications.

Typical Lamp Characteristics		
Lamp Type	Typical LPW	Rated Life (in hours)
Incandescent	5-22	750-2000
Halogen	12-36	2,000-6000
Compact Fluorescent	27-80	9,000-20,000
Fluorescent	75-100	5,000-36,000
Mercury	50-60	12,000-24,000+
ConstantColor® CMH®	80-95	10,000-20,000
Multi-Vapor® Metal Halide	80-115	10,000-20,000
Lucalox® High Pressure Sodium	90-140	10,000-40,000

## Suggested Color Applications for HID Lamps

- CMH®:** Stores, people places, display, accent.
- MVR:** Stores, public spaces, industrial, gymnasiums, floodlighting signs and buildings, parking areas, sports.
- MVR/C:** Same as MVR - warmer color-diffuse coating reducing glare.
- MVR/SP30:** Same as MVR-warmer than MVR or MVR/C - matches SP30 fluorescent.
- MXR:** Warm color (3200K) - good match for halogen.
- LU:** Street lighting, parking areas, industrial, floodlighting, security, CCTV.
- LU/DX:** Floodlighting, parking areas, indoor/outdoor pedestrian malls, industrial, security, roadway.
- Deluxe (DX) Mercury:** Stores, public spaces - metal halide lamps however, are preferred.
- Clear Mercury:** Landscape lighting, specialized floodlighting such as green copper roofs.

Incandescent  
Halogen  
High Intensity Discharge  
Fluorescent  
Compact Fluorescent  
Ballast  
LED Lamps and Systems  
Stage and Studio  
Miniature and Sealed Beam  
Projection

# High Intensity Discharge Lamps

## Product Information

### GE ConstantColor® CMH® Ceramic Metal Halide Lamps (pgs 3-9 to 3-11)

- Color uniformity lamp-to-lamp and over lamp life
- Excellent color rendering (80+ CRI, 90+ CRI for SPXX versions)
- Delivers more light than standard metal halide (10%–20% more)
- Lamp operates at high efficacy—up to 95 lumens per watt
- Many are universal burn—may be operated in any position
- Perfect for retail and commercial display lighting, accent and floodlighting, lobby and foyer lighting. Ideal for “people places”

### GE CMH® Chromafit™ Ceramic Metal Halide Lamps (pg 3-11)

- Convert High Pressure Sodium sockets to crisp, white ceramic metal halide light (80+ CRI)
- Operate on standard HPS ballasts and auxiliary equipment
- Universal burn—may be operated in any position
- Uses: Area lighting, industrial and “people places”
- Enclosed glass fixtures only

### GE PulseArc® Medium Based Metal Halide Lamps (/MED models) (pg 3-11)

- Low wattage metal halide lamps (formerly Halarc®) are now part of the PulseArc® family
- Compact source
- Sparkling white light (3000-4000K) and very good color rendition (70-75 CRI)
- High efficacy—more than 3 times the lumens per watt of incandescent
- Long life—up to 15 times longer than incandescent systems and up to 7 times longer than most PAR and R systems, saving maintenance and labor costs
- Superior optical control
- Uses: Display lighting, downlighting, floodlighting, corridors, lobbies, walkways; retail, office, commercial

### GE PulseArc® Multi-Vapor® Metal Halide Lamps (/PA Models) (pg 3-11 to 3-12)

- Designed for operation only on approved ballasts with metal halide pulse ignitors
- More light—400W lamps provide highest initial and highest maintained lumens versus other standard universal or vertical base-up lamp options
- 50% longer life—400W lamps provide 30,000 hours life when burned on 120 hour on/1 hour off cycle (approximately continuous)
- Faster hot restrike—less than 4 minutes versus 10-15 minutes for typical metal halide lamps

### GE Multi-Vapor® Metal Halide Lamps (pgs 3-12 to 3-13)

- Sparkling white light (3000-4000K) and very good color rendition (65-75 CRI)
- Warm, rich 3000K color of SP30 blends well with incandescent, halogen and triphosphor fluorescent lamps for interior retail applications
- High efficacy—more efficient than incandescent, mercury and most fluorescent sources
- Long life—10,000-20,000 hours for most types

- Full line, 150-1000 watts, to meet most application needs
- Uses: Downlighting, floodlighting, corridors, lobbies, walkways; retail, commercial, industrial

### GE High Output Multi-Vapor® Lamps (pg 3-13)

- More light—optimized for higher light output in horizontal, vertical base-up and base-down burn applications
  - Horizontal burn lamps provide up to 25% more light than standard universal burn equivalents
  - 400W vertical burn lamps provide up to 22% more light than standard universal burn equivalents; the highest lumen lamps available for operation on standard M59 ballasts
- Longer life—horizontal burn lamps last up to 67% longer than universal burn lamp equivalents, significantly reducing replacement lamp and maintenance costs

### GE Protected High Output Multi-Vapor® Lamps (/O) (pg 3-14)

- Protective quartz jacket surrounds the arc tube
- The/O suffix and/or the “MPR” prefix in the Lamp Description indicates lamps are suitable for open fixture applications

### GE ChromaFit™ Multi-Vapor® Lamps (/R) (pg 3-14)

- Convert high pressure sodium sockets to crisp white metal halide light (65-70 CRI)
- Operate on standard HPS ballasts and auxiliary equipment
- Uses: Area lighting, industrial and “people places”

### GE I-Line Multi-Vapor® Lamps (pg 3-14 to 3-15)

- Convert mercury sockets to crisp, white metal halide light
- More light, better color, energy cost savings for mercury users
- 40%-100% more light than existing mercury lamps
- Operate on standard CW and CWA mercury ballasts and auxiliary equipment

### GE Saf-T-Gard® Multi-Vapor Lamps (MVT) (pg 3-15)

- Special self-extinguishing feature prevents exposure to UV in case outer bulb is punctured or broken; lamp turns off within 15 minutes
- Meets requirements of Federal Standard 21CFR1040.30
- Saf-T-Gard® I-Line lamps convert mercury sockets to crisp, white metal halide light
- Saf-T-Gard® I-Line lamps operate on standard mercury ballasts and auxiliary equipment
- Uses: Industrial, commercial, gymnasiums, sports complexes, especially where open fixtures are used and risk of outer bulb breakage is possible

### GE Arcstream® Metal Halide Lamps (pg 3-15)

- Compact size, white light, excellent color
- Precise optical control delivers a concentrated beam of light right where it's needed
- Variety of color temperatures (3,000K-6,000K)
- PAR64: ideal for long-range projection and sports lighting applications
- Uses: Ideal for retail and commercial display lighting, floodlighting, accent/highlighting

### GE Lucalox® High Pressure Sodium Lamps (pg 3-15)

- Very high efficacy/low operating cost
- Excellent lumen maintenance—over 90% @ 50% of life
- Very long life—24,000+ hours
- Universal burn—can be operated in any position without affecting performance
- Warm color
- For open or enclosed fixtures
- Uses: Industrial, roadway, security, floodlighting

### GE Double-Ended Lucalox® Lamps (/TD) (pg 3-15)

- Compact tubular design fits compact fixtures for excellent optical control
- High efficacy, lumen maintenance and long life of standard Lucalox® HPS

### GE Ecolux® High Pressure Sodium Lamps (/ECO) (pgs 3-15 to 3-16)

- Lead-free base. Passes TCLP, which can lower disposal costs.

### GE Standby Longlife Lucalox® Lamps (/SBY) (pgs 3-16 to 3-17)

- Extra arc tube provides light instantly after momentary power interruption, and will increase to 80% light output in 1-2 minutes
- Dual arc tubes provide 40,000 hour rated life
- Operates on standard HPS ballasts and auxiliary equipment
- Uses: Industrial, roadway, security, and hard-to-reach sockets

### GE Ecolux® NC “Non-Cycling” High Pressure Sodium Lamps (/ECO/NC) (pg 3-17)

- Low mercury. Passes TCLP, which can lower disposal costs.
- Non-cycling feature makes locating and replacing end-of-life lamps quick and easy
- Lead-free base
- High efficacy/low operating cost
- 6%-11% higher initial lumens than standard HPS in 100W and 400W versions
- Long life—30,000 hours
- Open or enclosed fixtures
- Uses: Industrial, roadway, security

### GE Deluxe Lucalox® High Pressure Sodium Lamps (pg 3-17)

- High efficacy, lumen maintenance and long life of standard Lucalox® HPS
- High color rendering (65-70CRI), much better than standard HPS
- Blends well with incandescent and standard HPS sources
- Operates on standard HPS ballasts and auxiliary equipment
- Uses: Storage rooms, industrial facilities, offices, gymnasiums, malls, parks, building floodlighting

### GE E-Z Lux® High Pressure Sodium Lamps (pg 3-17)

- Direct replacement for mercury lamps on mercury ballasts
- More efficient, 57-114% more lumens and 10-14% fewer watts than mercury lamps they replace
- Uses: General lighting, roadway
- See operating notes for further information

### GE Mercury Lamps (pgs 3-17 to 3-18)

- Long life and good efficacy
- Phosphor coated Deluxe lamps provide good color rendering (50CRI)
- Uses: Industrial, roadway, landscapes, residential and commercial security, parking lots

### GE Saf-T-Gard® Mercury Lamps (pg 3-18)

- Special self-extinguishing feature prevents exposure to harmful UV in case outer bulb is punctured or broken; lamp turns off within 15 minutes
- Meets requirements of Federal Standard 21 CFR 1040.30
- See operating notes for further information

### GE E-Z Merc® Self-Ballasted Mercury Lamps (pg 3-18)

- Retrofit incandescent sockets to longer-life mercury lamps without additional mercury ballasts or auxiliary equipment

### GE Export Base Lamps (pg 3-18)

- Export-only lamps are not sold or intended for use in North America. The lamps are identified by “/27” or “/40” at the end of the lamp description, and comply with electrical characteristics defined by IEC standards.
- Bulb shapes are generally similar to U.S. lamp types. Refer to drawings on pages 3-2 to 3-5.

# High Intensity Discharge Lamps

## HID Brand Name Cross-Reference

GE	OSRAM/SYLVANIA	PHILIPS
Arcstream® MQI	BRITE-LINE™, HQI®	MHN-TD
ChromaFit™ Multi-Vapor®	—	—
ConstantColor® CMH®	Powerball® MCP	MasterColor® CDM
Deluxe Lucalox®	—	Ceramalux™ Comfort
E-Z Lux®	Unalux®	Ceramalux™ Retrolux
E-Z Merc®	—	Self-Ballasted Mercury
Ecolux®	Lumalux ECO®	Ceramalux Alto®
Ecolux® NC	Lumalux Plus™/ECO®	Ceramalux Alto® Plus
High Output Multi-Vapor®	Super Metalarc®	Metal Halide
Horizontal Multi-Vapor®	Super Metalarc®	—
I-Line Multi-Vapor®	—	—
Lucalox®	Lumalux®	Ceramalux™
Multi-Vapor®	Metalarc®	Metal Halide
Protected High Output Multi-Vapor®	Metalarc® Pro-Tech™	—

GE	OSRAM/SYLVANIA	PHILIPS
PulseArc®	Super Metalarc® Pulse Start	Pulse Start
Saf-T-Gard® Mercury	Mercury Safeline®	Safety Lifeguard Mercury
Saf-T-Gard® Multi-Vapor®	Metalarc® Safeline®	Safety Lifeguard Metal Halide
Standby Longlife Lucalox®	Lumalux® Standby	Instant Restrike Ceramalux™
Watt-Miser® Multi-Vapor®	Metalarc® Supersaver®	—

**ATTENTION:** This brand-name cross-reference chart is provided only as a quick reference. Other lamp company brand listings may only represent a near equivalent, versus an identical match to GE Lighting brands. Individual lamp manufacturers' performance specifications should be consulted. Lamp performance may be affected by environmental conditions, ballast type and/or other auxiliary equipment.

## Headings in this catalog section

The following terms and descriptions can help you when checking High Intensity Discharge lamp specifications and when ordering products. Within each product line, lamps are divided into families. Within families, lamps are listed by wattage. In each of these wattage groups, lamps are listed by bulb shape.

### Bulb Shape:

Bulb shape followed by its size (the maximum diameter of the bulb expressed in eighths of an inch).

### Energy Used – Nominal Watts:

Energy Used (as defined by FTC Lamp Label Rules). To estimate energy consumption (kWh), multiply watts x hours of use and divide by 1000.

### Mean Lumens:

Lamp light output (lumens) at 40% of rated lamp life for Metal Halide lamps and 50% of rated life for Mercury and HPS lamps.

### Color Temperature Kelvins (K):

A measure of the visual "warmth" or "coolness" of the light from the lamp. The higher the value the whiter or "cooler" the light appears.

### Color Rendering Index (CRI):

An indication of the ability of the lamp to render object colors in a normal, natural way. The higher the number (0-100), the better the color appearance.

### CBCP (Center Beam Candlepower):

For reflector-type lamps, Center Beam Candlepower is the intensity (candelas) at the center or maximum intensity of the beam. Used only for ConstantColor® CMH® Metal Halide Lamps.

### Order Code:

It is important to use this five-digit code when ordering to ensure that you receive the exact product you require.

### ANSI Ballast Type:

Ballast type used to operate lamp.

### Initial Lumens:

Initial light output.

### Rated Life (hours):

Lamp burning hours to median life expectancy.

### Additional Information:

Typical application and/or other important information.

### Footnotes:

See page 3-20.

### Warning and Caution Notices:

See page 3-21.

Bulb Shape	Base	LET	OP	Watts	MOL (in)	LCL (in)	Order Code	Description	ANSI Ballast Type	Case Qty	CBCP	Rated Life (hrs)	Initial Lumens	Mean Lumens	Color Temp K	CRI	Additional Information	Footnotes	Warning and Caution Notices
------------	------	-----	----	-------	----------	----------	------------	-------------	-------------------	----------	------	------------------	----------------	-------------	--------------	-----	------------------------	-----------	-----------------------------

### Constant Color CMH® Metal Halide Lamps

CMH® MR16																			
MR16	GX10	O	U	20	2.28		85101	CMH20MR16/830/SP	M156	12	9000	12000	1000		3000	81	12 Spotlight, UV control	33,39,51	107

**CMH20MR16 / 830 / SP**

Identifies as CMH® lamp. Identifies the lamp's wattage. Identifies the bulb shape. Color temp. and CRI. Additional information.

### WHEN YOU DON'T KNOW THE LAMP DESCRIPTION

1. Identify bulb shape by using illustrations on pages 3-2 to 3-5.
2. Measure bulb diameter using ruler in Appendix section page A-1 to determine width in eighths of an inch.
3. Identify base type using table on page 3-5.
4. Find your lamp in the tabular data containing the bulb shape, size and base, which are all listed by wattage.

Bulb Shape	Base	LET	OP	Watts	MOL (in)	LCL (in)	Order Code	Description	ANSI Ballast Type	Case Qty	CBCP	Rated Life (hrs)	Initial Lumens	Mean Lumens	Color Temp K	CRI	Additional Information	Reduced Watts/High Color Rendering	Footnotes	Warning and Caution Notices		
Constant Color CMH® Metal Halide Lamps																						
CMH® MR16																						
MR16	GX10	O	U	20	2.28		85101	CMH20MR16/830/SP	M156	12	9000	12000	1000		3000	81	12 Spotlight, UV Control		33,39,51	107		
				20	2.28		85110	CMH20MR16/830/FL	M156	12	2900	12000	1000		3000	81	25 Floodlight, UV Control		33,39,51	107		
				20	2.28		97638	CMH20MR16/830WFL	M156	12	1500	12000	1000		3000	81	40 Wide Flood, UV Control		33,39,51	107		
		O	U	39	2.28		71488	CMH39MR16/930/SP	M130	12	16000	10000	2100		3000	90	12 Spotlight, UV Control		33,39,51	107		
					2.28		71489	CMH39MR16/930/FL	M130	12	5500	10000	2100		3000	90	25 Floodlight, UV Control		33,39,51	107		
					2.28		71490	CMH39MR16/930WFL	M130	12	3000	10000	2100		3000	90	40 Wide Flood, UV Control		33,39,51	107		
		O	U	39	2.28		17491	CMH39MR16/942/SP	M130	12	16000	12000	2100		4000	92	12 Spotlight, UV Control		33,39,51	107		
					2.28		71492	CMH39MR16/942/FL	M130	12	5500	12000	2100		4000	92	25 Floodlight, UV Control		33,39,51	107		
					2.28		71493	CMH39MR16/942WFL	M130	12	3000	12000	2100		4000	92	40 Wide Flood, UV Control		33,39,51	107		
CMH® PAR																						
PAR20	E26	O	U	20	3.60		29485	CMH20PAR20/SP	M156	15	13000	12000	1000		3000	81	8 Spotlight, UV Control		33,39,51	107		
				20	3.60		29486	CMH20PAR20/FL	M156	15	3750	12000	1000		3000	81	25 Floodlight, UV Control		33,39,51	107		
PAR30L	E26	O	U	20	4.75		29487	CMH20PAR30/SP10	M156	6	19800	12000	1200		3000	81	10 Spotlight, UV Control		33,39,51	107		
				20	4.75		29488	CMH20PAR30/SP15	M156	6	14500	12000	1200		3000	81	15 Spotlight, UV Control		33,39,51	107		
				20	4.75		29489	CMH20PAR30/FL25	M156	6	4900	12000	1200		3000	81	25 Floodlight, UV Control		33,39,51	107		
PAR20	E26	O	U	39	3.60		42068	CMH39UPAR20FL25	M130	15	7500	10000	2100		3000	86	25 Floodlight, UV Control		33,39,45	107		
				39	3.60		42069	CMH39UPAR20SP10	M130	15	22000	10000	2100		3000	86	10 Spotlight, UV Control		33,39,45	107		
		O	U	39	3.60		96526	CMH39PAR20/NSP4K	M130	15	19450	10000	1950		4200	90	10 Spotlight, UV Control		33,39,45	107		
				39	3.60		96527	CMH39PAR20/FL4K	M130	15	6950	10000	1950		4200	90	25 Floodlight, UV Control		33,39,45	107		
PAR30L	E26	O	U	39	4.75		42066	CMH39PAR30L/SP15	M130	6	29000	10000	2400		3000	81	15 Spotlight, UV Control		33,39,45	107		
				39	4.75		42067	CMH39PAR30L/FL25	M130	6	11000	10000	2400		3000	81	25 Floodlight, UV Control		33,39,45	107		
		O	U	39	4.75		45066	CMH39/PAR30LSP10	M130	6	39600	10000	2400		3000	81	10 Spotlight, UV Control		33,39,45	107		
					4.75		96528	CMH39PAR30LNSP4K	M130	6	36700	10000	2225		4200	89	10 Spotlight, UV Control		33,39,45	107		
		O	U	39	4.75		96529	CMH39PAR30L/SP4K	M130	6	26900	10000	2225		4200	89	15 Spotlight, UV Control		33,39,45	107		
					4.75		96530	CMH39PAR30L/FL4K	M130	6	10200	10000	2225		4200	89	25 Floodlight, UV Control		33,39,45	107		
		O	U	70	4.75		22152	CMH70PAR30L830SP	M139/M98	6	43000	13000	4700		3000	82	15 Spotlight, UV Control		33,39,45	107		
					4.75		22159	CMH70PAR30L830FL	M139/M98	6	10000	13000	4700		3000	82	40 Floodlight, UV Control		33,39,45	107		
		PAR38	E26	O	U	70	5.31		45675	CMH70PAR38SP/ECO	M143/M98	6	40000	10000	4800		3000	82	15 Spotlight, UV Control		33,39	108
						70	5.31		45677	CMH70PAR38FL/ECO	M143/M98	6	14000	10000	4800		3000	82	25 Floodlight, UV Control		33,39	108
O	U			70	5.31		45679	CMH70PAR38WF/ECO	M143/M98	6	4400	10000	4800		3000	82	60 Wide Floodlight, UV Control		33,39	108		
					5.31		45680	CMH100PAR38SPECO	M140/M90	6	45000	10000	6500		3000	81	15 Spotlight, UV Control		33,39	108		
O	U			100	5.31		45681	CMH100PAR38FLECO	M140/M90	6	15000	10000	6500		3000	81	25 Floodlight, UV Control		33,39	108		
					5.31		45682	CMH100PAR38WFECO	M140/M90	6	5500	10000	6500		3000	81	60 Wide Floodlight, UV Control		33,39	108		
PAR56	GX16D	E	U	150	5.00		88517	CMH150/PAR56/WFL/942	M102/M142	6	17000	5000		4200	90	Wide Flood		33,39	108			
				150	5.00		88518	CMH150/PAR56/MFL/942	M102/M142	6	40000	5000		4200	90	Medium Flood		33,39	108			
		E	U	150	5.00		88519	CMH150/PAR56/SP/942	M102/M142	6	85000	5000		4200	90	Spot		33,39	108			
					5.00		88520	CMH150/PAR56/WFL/830	M102/M142	6	17000	5000		3000	80	Wide Flood		33,39	108			

Incandescent  
Halogen  
High Intensity Discharge  
Fluorescent  
Compact Fluorescent  
Ballast  
LED Lamps and Systems  
Stage and Studio  
Miniature and Sealed Beam  
Projection

# High Intensity Discharge Lamps

Bulb Shape	Base	LET	OP	Watts	MOL (in)	LCL (in)	Order Code	Description	ANSI Ballast Type	Case Qty	CBCP	Rated Life (hrs)	Initial Lumens	Mean Lumens	Color Temp K	CRI	Additional Information	Reduced Watts/High Color Rendering	Footnotes	Warning and Caution Notices
<b>Constant Color CMH® Metal Halide Lamps (continued)</b>																				
<b>CMH® PAR (continued)</b>																				
PAR56	GX16D	E	U	150	5.00		88521	CMH150/PAR56/MFL/830	M102/M142	6	40000	5000			3000	80	Medium Flood		33,39	108
		E	U	150	5.00		88522	CMH150/PAR56/SP/830	M102/M142	6	85000	5000			3000	80	Spot		33,39	108
PAR64	GX16D	E	U	150	6.42		88541	CMH150/PAR64/WFL/942	M102/M142	6	16000	8000			4200	90	Wide Flood		33,39	108
		E	U	150	6.42		88542	CMH150/PAR64/MFL/942	M102/M142	6	47000	8000			4200	90	Medium Flood		33,39	108
		E	U	150	6.42		88543	CMH150/PAR64/SP/942	M102/M142	6	154000	8000			4200	90	Spot		33,39	108
		E	U	150	6.42		88544	CMH150/PAR64/WFL/830	M102/M142	6	16000	8000			3000	80	Wide Flood		33,39	108
		E	U	150	6.42		88537	CMH150/PAR64/MFL/830	M102/M142	6	47000	8000			3000	80	Medium Flood		33,39	108
		E	U	150	6.42		88545	CMH150/PAR64/SP/830	M102/M142	6	154000	8000			3000	80	Spot		33,39	108
<b>CMH® Elliptical</b>																				
BD17	E26	E	U	70	5.43	3.37	22119	CMH70/U/830/MED	M139/M98/C98	6		15000	6300	4100	3000	80	Clear		33	116
		E	U	70	5.43	3.37	22124	CMH70/C/U/830MED	M139/M98/C98	6		15000	6000	4000	3000	80	Coated		33	116
		E	U	100	5.43	3.37	22127	CMH100/U/830/MED	M140/M90	6		10000 V 15000 H	9200	6600 V 6400 H	3000	83	Clear		33	116
		E	U	100	5.43	3.37	22137	CMH100/C/U830MED	M140/M90	6		10000 V 15000 H	8700	6300	3000	83	Coated		33	116
<b>CMH® Elliptical Open-Rated</b>																				
ED17	E26	O	U	70	5.43	3.37	31069	CMH70U830MED/O	M143/M98/C98	6		15000	5700	4100	3000	80	Clear		33	106
		O	U	70	5.43	3.37	31070	CMH70CU830MED/O	M143/M98/C98	6		15000	5700	4100	3000	80	Coated		33	106
		O	U	70	5.43	3.37	31073	CMH70U942MED/O	M143/M98/C98	6		15000	5500	4200	4000	90	Clear		33	106
		O	U	70	5.43	3.37	31074	CMH70CU942MED/O	M143/M98/C98	6		15000	5200	4000	4000	90	Coated		33	106
		O	U	150	5.43	3.37	31065	CMH150U830MED/O	M102/M142	6		12000	12900	9500	3000	80	Clear		33	106
		O	U	150	5.43	3.37	31066	CMH150CU830MED/O	M102/M142	6		12000	11900	8800	3000	80	Coated		33	106
		O	U	150	5.43	3.37	31067	CMH150U942MED/O	M102/M142	6		15000	12000	9000	4200	90	Clear		33	106
		O	U	150	5.43	3.37	31068	CMH150CU942MED/O	M102/M142	6		15000	11000	8300	4200	90	Coated		33	106
<b>CMH® Single-Ended G12 ULTRA</b>																				
T6	G12	E	U	70	3.56	2.18	73056	CMH70U930G12ULR	C139/M139	12		15000	6400	5600	3000	87	UV Control		33,39,45	104
<b>CMH® Single-Ended G12</b>																				
T4.5	G12	E	U	20	3.56	2.18	29703	CMH20T/U/830/G12	M156	12		12000	1600	1200	3000	81	UV Control		33,39,51	104
		E	U	39	3.56	2.18	20153	CMH39TUVCU830G12	M130	12		15000	3400	2300	3000	84	UV Control		33,39,45	104
		E	U	39	3.56	2.18	29696	CMH39TU/942/G12	M130	12		12000	3150	2700	4200	88	UV Control		33,39,45	104
T6	G12	E	U	70	3.56	2.18	20016	CMH70TU/830/G12	C139/M139	12		15000	6200	4700	3000	83	UV Control		33,39,45	104
		E	U	70	3.56	2.18	20023	CMH70TU/942/G12	C139/M139	12		15000	6000	4600	4200	93	UV Control		33,39,45	104
		E	U	150	3.93	2.18	20017	CMH150TU/830/G12	M102/M142	12		12000	14000	11000	3000	82	UV Control		33,39,45	104
		E	U	150	3.93	2.18	20018	CMH150TU/942/G12	M102/M142	12		12000	13000	11000	4200	94	UV Control		33,39,45	104
		<b>CMH® Double-Ended TD</b>																		
T6	Rx7s	E	H45	70	4.50	2.25	92587	CMH70/TD/830RX7S	M85/M139	12		15000	7000	5600	3000	81	UV Control		33,39	109
		E	H45	70	4.50	2.25	92588	CMH70/TD/942RX7S	M85/M139	12		15000	7000	5600	4200	88	UV Control		33,39	109
T7	Rx7s	E	H45	150	5.37	2.62	92589	CMH150TD830RX7S	M81/M142	12		15000	14000	11500	3000	80	UV Control		33,39	109
		E	H45	150	5.37	2.62	92590	CMH150TD942RX7S	M81/M142	12		15000	14000	11500	4200	93	UV Control		33,39	109

For the most up-to-date product information, see [www.gelighting.com](http://www.gelighting.com). To convert inches to millimeters, multiply by 25.4. All footnotes, warning and caution notices found at the end of this section (page 3-20).

Bulb Shape	Base	LET	OP	Watts	MOL (in)	LCL (in)	Order Code	Description	ANSI Ballast Type	Case Qty	CBCP	Rated Life (hrs)	Initial Lumens	Mean Lumens	Color Temp K	CRI	Additional Information	Reduced Watts/High Color Rendering	Footnotes	Warning and Caution Notices	
<b>Constant Color CMH® Metal Halide Lamps (continued)</b>																					
<b>CMH® GU6.5</b>																					
T4	GU6.5	E	U	20	2.05	1.18	85086	CMH20T/U830GU6.5	M156	12		12000	1615	1066	3000	81	UV Control		33,39,51	104	
		E	U	39	2.05	1.18	71484	CMH39T/U930GU6.5	M130	12		10000	3400	2300	3000	88	UV Control		33,39,51	104	
		E	U	39	2.05	1.18	71487	CMH39T/U942GU6.5	M130	12		12000	3400	2600	4000	90	UV Control		33,39,51	104	
<b>CMH® Mini ULTRA</b>																					
T4.5	G8.5	E	U	70	3.37	2.00	73057	CMH70U930G8.5ULR	C139/M139	12		15000	6200	5400	3000	88	UV Control		33,39,45	104	
<b>CMH® Mini's</b>																					
T4.5	G8.5	E	U	20	3.37	2.00	92696	CMH20TCU830/G8.5	M156	12		12000	1650	1090	3000	81	UV Control		33,39,51	104	
		E	U	39	3.37	2.00	90352	CMH39TCU830/G8.5	M130	12		15000	3400	2300	3000	84	UV Control		33,39,45	104	
		E	U	39	3.37	2.00	29698	CMH39TCU942/G8.5	M130	12		12000	3150	2700	4200	88	UV Control		33,39,45	104	
		E	U	70	3.37	2.00	92585	CMH70TCU830G8.5	C139/M139	12		15000	6200	4400	3000	83	UV Control		33,39,45	104	
		E	U	70	3.37	2.00	29701	CMH70TCU942/G8.5	C139/M139	12		15000	6000	4600	4200	90	UV Control		33,39,45	104	
<b>CMH® Chromafit™</b>																					
T15	E39	E	U	250	9.75	5.75	93357	CMH250/U/830/R	S50/M168	12		20000	25000	20000	3000	85			33	105	
ED18	E39	E	U	400	9.75	5.75	93295	CMH400/U/830/R	S51/M169	12		20000	41000	31300	3000H 3600V	82H 80V				33,45,49	105
<b>High-Watt CMH® SPXX</b>																					
ED28	EX39	O	V	250	8.31	5.00	48429	CMH250/V/PA/O		12		20000	23000	18400	4100	90	Clear		33,45,52	106	
		O	V	250	8.31	5.00	48432	CMH250C/V/PA/O		12		20000	22000	17600	4100	90	Coated		33,45,52	106	
ED37	EX39	O	V	320	11.31	7.00	17264	CMH320/V/PA/O		6		20000	31000	24800	4100	90	Clear		33,45,52	106	
		O	V	320	11.31	7.00	17267	CMH320C/V/PA/O		6		20000	30000	24000	4100	90	Coated		33,45,52	106	
		O	V	350	11.31	7.00	20035	CMH350/V/PA/O		6		20000	33000	26400	4000	90	Clear		33,45,52	106	
		O	V	350	11.31	7.00	20036	CMH350C/V/PA/O		6		20000	32000	25600	4000	90	Coated		33,45,52	106	
		O	V	400	11.31	7.00	49910	CMH400/V/PA/O		6		20000	40000	32000	3700	92	Clear		33,45,52	106	
		O	V	400	11.31	7.00	49911	CMH400C/V/PA/O		6		20000	39000	31200	3700	92	Coated		33,45,52	106	
<b>PulseArc™ Multi-Vapor® Metal Halide Lamps</b>																					
<b>50 Watts</b>																					
BD17	E26	E	U	50	5.43	3.43	10361	MXR50/U/MED	M110	6		10000	3200	2100	3700	60	Clear			118	
		E	U	50	5.43	3.43	10364	MXR50/C/U/MED	M110	6		10000	3000	2000	3400	65	Coated			118	
<b>70 Watts</b>																					
BD17	E26	E	U	70	5.43	3.43	22158	MXR70/U/MED	M98	6		12000	5500	3500	3200	70	Clear			118	
		E	U	70	5.43	3.43	22162	MXR70/C/U/MED	M98	6		12000	5300	3300	3200	70	Coated			118	
		E	U	70	5.43	3.43	12590	MVR70/U/MED	M98	6		12000	4700	3000	4000	70	Clear			118	
		E	U	70	5.43	3.43	12594	MVR70/C/U/MED	M98	6		12000	4500	2800	4000	70	Coated			118	
<b>100 Watts</b>																					
BD17	E26	E	U	100	5.43	3.43	18680	MXR100/U/MED	M90	6		15000	9000	6200	3200	70	Clear			118	
		E	U	100	5.43	3.43	18679	MXR100/C/U/MED	M90	6		15000	8500	5900	3200	70	Coated			118	
		E	U	100	5.43	3.43	126														

# High Intensity Discharge Lamps

Bulb Shape	Base	LET	OP	Watts	MOL (in)	LCL (in)	Order Code	Description	ANSI Ballast Type	Case Qty	CBCP	Rated Life (hrs)	Initial Lumens	Mean Lumens	Color Temp K	CRI	Additional Information	Reduced Watts/High Color Rendering	Footnotes	Warning and Caution Notices
<b>PulseArc™ Multi-Vapor® Metal Halide Lamps (continued)</b>																				
<b>320 Watts</b>																				
ED28	E39	E	VBU	320	8.25	5.00	27501	MVR320/VBU/HO/PA	M132/M154	12		20000	31000	18000	4000	65	Clear		43	117
		E	VBU	320	8.25	5.00	27502	MVR320/C/VBUHOPA	M132/M154	12		20000	30000	16500	3700	70	Coated		43	117
		E	VBU	320	8.25	5.00	45666	MVR320VBU/XHO/PA	M132/M154	12		20000	34000	25000	4000	65	Extra High Output		43	116
		E	VBU	320	8.25	5.00	45669	MVR320/C/VBU/XHO/PA	M132/M154	12		20000	33000	23000	3700	70	Extra High Output		43	116
		E	HOR	320	8.25	5.00	72884	MVR320/HOR/PA	M132/M154	12		20000	30000	19100	4100	65	Clear		43	117
<b>350 Watts</b>																				
ED37	E39	E	VBU	350	11.50	7.00	23729	MVR350VBUHOPA/E	M131	6		20000	36500	27000	4000	65	Extra High Output		43	117
		E	VBU	350	11.50	7.00	23738	MVR350CVBUHOPA/E	M131	6		20000	34500	25000	3700	65	Extra High Output		43	117
<b>400 Watts</b>																				
ED37	E39	S	VBU	400	11.50	7.00	45664	MVR400/VBU/HO/PA	M135/M155	6		20000	41000	31000	4000	65	Clear		43, 49	121
		S	VBU	400	11.50	7.00	12642	MVR400/VBU/XHOPA	M135/M155	6		20000	44000	33000	4000	65	Extra High Output		43, 49	121
		S	VBU	400	11.50	7.00	12644	MVR400/CVBUHOPA	M135/M155	6		20000	42000	31500	3700	70	Coated, Extra High Output		43, 49	121
		E	HOR	400	11.50	7.00	72886	MVR400/HOR/PA	M135/M155	6		20000	40000	22300	4100	65	Clear		43, 49	116
		E	VBD	400	11.50	7.00	46632	MVR400VBD/XHO/PA	M135	6		20000	44000	35200	4000	65	Extra High Output		43, 49	116
ED28	E39	E	VBU	400	8.25	5.00	46271	MVR400/VBUED28PA	M135/M155	12		20000	44000	28500	4000	65	Clear		43, 49	116
		E	VBU	400	8.25	5.00	46272	MVR400CVBUED28PA	M135/M155	12		20000	42000	27500	3700	70	Coated Compact		43, 49	116
		E	HOR	400	8.25	5.00	72885	MVR400/HOR/ED28/PA	M135/M155	12		20000	38000	15400	4100	65	Clear Compact		43, 49	116
<b>750 Watts</b>																				
BT37	E39	E	VBU	750	11.50	7.00	27219	MVR750/VBU/PA	M149	6		16000	82000	60000	4000	65	Clear		49	117
		E	VBU	750	11.50	7.00	45560	MVR750/C/VBU/PA	M149	6		16000	72000	54000	3700	70	Coated		49	117
<b>1000 Watts</b>																				
BT37	E39	E	U	1000	11.30	7.00	10389	MVR1000/BT37/PA	M141	6		9000H/12000V	105000H/115000V	82000H/90000V	3900	65	Clear		43, 49	116
<b>Multi-Vapor® Metal Halide Lamps</b>																				
<b>150 Watts</b>																				
ED28	E39	E	U	150	8.25	5.00	13481	MVR150/U/WM	M57/M107	12		7500H/10000V	11500H/13500V	7200H/8500V	4000	65	Clear, Watt-Miser®	↔		117
		E	U	150	8.25	5.00	13490	MVR150/C/U/WM	M57/M107	12		7500H/10000V	10900H/12800V	6900H/8000V	3700	70	Coated, Watt-Miser®	↔		117
<b>175 Watts</b>																				
BD17	E26	E	U	175	5.75	3.43	18902	MVR175/U/MED	M57	6		6000H/10000V	11700H/13600V	7400H/8800V	4000	65	Clear			117
		E	U	175	5.75	3.43	26432	MVR175/U/MED/CP	M57	4		6000H/10000V	11700H/13600V	7400H/8800V	4000	65	Clear, Consumer Pack			117
		E	U	175	5.75	3.43	19976	MVR175/C/U/MED	M57	6		6000H/10000V	11900H/12900V	7900H/8400V	3900	65	Coated			117
ED28	E39	E	U	175	8.25	5.00	47760	MVR175/U	M57	12		6000H/10000V	11700H/13600V	7900H/8800V	4000	65	Clear			117
		E	U	175	8.25	5.00	26433	MVR175/U/CP	M57	4		6000H/10000V	11700H/13600V	7900H/8800V	4000	65	Clear, Consumer Pack			117
		E	U	175	8.25	5.00	47761	MVR175/C/U	M57	12		6000H/10000V	11900H/12900V	7900H/8400V	3900	70	Coated			117
		E	U	175	8.25	5.00	17634	MVR175/SP30/U	M57	12		6000H/10000V	10300H/12000V	6500H/7600V	3000	70	RE730 Phosphor Coating			117
PAR38	E26	E	U	175	5.62		25218	MVR175/PAR38/FL1	M57	6	6500		7500	12000		3800	65	Clear, One-Piece PAR		117
<b>250 Watts</b>																				
ED28	E39	E	U	250	8.25	5.00	42729	MVR250/U	M58	12		6000H/10000V	19100H/20800V	12400H/13500V	4200	65	Clear			117
		E	U	250	8.25	5.00	26434	MVR250/U/CP	M58	4		6000H/10000V	19100H/20800V	12400H/13500V	4200	65	Clear, Consumer Pack			117
		E	U	250	8.25	5.00	42731	MVR250/C/U	M58	12		6000H/10000V	18200H/19800V	11600H/13000V	3900	70	Coated			117
		E	U	250	8.25	5.00	17633	MVR250/SP30/U	M58	12		6000H/10000V	16600H/18000V	10600H/11500V	3000	70	RE730 Phosphor Coating			117
<b>360 Watts</b>																				
ED37	E39	S	VBU	360	11.50	7.00	13495	MVR360/VBU/WM/HO	M59/M165	6		20000	36000	23500	4300	65	Clear, Watt-Miser®	↔	32, 49	121

For the most up-to-date product information, see [www.gelighting.com](http://www.gelighting.com). To convert inches to millimeters, multiply by 25.4. All footnotes, warning and caution notices found at the end of this section (page 3-20).

Bulb Shape	Base	LET	OP	Watts	MOL (in)	LCL (in)	Order Code	Description	ANSI Ballast Type	Case Qty	CBCP	Rated Life (hrs)	Initial Lumens	Mean Lumens	Color Temp K	CRI	Additional Information	Reduced Watts/High Color Rendering	Footnotes	Warning and Caution Notices
<b>Multi-Vapor® Metal Halide Lamps (continued)</b>																				
<b>400 Watts</b>																				
ED37	E39	S	U	400	11.50	7.00	43828	MVR400/U	M59	6		15000H/20000V	33100H/36000V	22100H/23500V	4000	65	Clear		49	121
		S	U	400	11.50	7.00	26435	MVR400/U/CP	M59	4		15000H/20000V	33100H/36000V	22100H/23500V	4000	65	Clear, Consumer Pack		49	121
		S	U	400	11.50	7.00	43829	MVR400/C/U	M59	6		15000H/20000V	32200H/35000V	19300H/23000V	3700	70	Coated		49	121
		S	U	400	11.50	7.00	17632	MVR400/SP30/U	M59	6		15000H/20000V	28500H/31000V	17100H/18600V	3000	70	RE730 Phosphor Coating		49	121
ED28	E39	E	U	400	8.25	5.00	18904	MVR400/U/ED28	M59	12		15000H/20000V	33100H/36000V	22100H/23500V	4000	65	Clear, Compact		49	117
		E	U	400	8.25	5.00	19979	MVR400/C/U/ED28	M59	12		15000H/20000V	32200H/35000V	19300H/23000V	4000	65	Coated, Compact		49	117
<b>1000 Watts</b>																				
BT56	E39	S	U	1000	15.37	9.50	41826	MVR1000/U	M47	6		11000H/15000V	100280H/108000V	79000H/86000V	4000	65	Clear		49	121
		S	U	1000	15.37	9.50	41827	MVR1000/C/U	M47	6		11000H/15000V	96600H/105000V	73000H/80000V	3700	65	Coated		49	121
BT37	E39	E	U	1000	11.50	7.00	18205	MVR1000/U/BT37	M47	6		9000H/12000V	105000H/115000V	82000H/90000V	3700	65	Clear, Compact		49	121
<b>High Output and XHO Multi-Vapor® Metal Halide Lamps</b>																				
<b>175 Watts</b>																				
ED28	PosMog	E	HOR	175	8.25	5.00	18104	MVR175/HOR	M57	12		10000	15000	7700	4000	65	Clear, Position Oriented Socket			117
		E	HOR	175	8.25	5.00	18105	MVR175/C/HOR	M57	12		10000	14100	7500	3500	70	Coated, Position Oriented Socket			117
<b>250 Watts</b>																				
ED28	PosMog	E	HOR	250	8.25	5.00	18101	MVR250/HOR	M58	12		15000	21000	10000	4200	65	Clear, Position Oriented Socket			117
		E	HOR	250	8.25	5.00	18103	MVR250/C/HOR	M58	12		15000	19700	9400	3600	70	Coated, Position Oriented Socket			117
<b>360 Watts - Watt-Miser® Energy-Saving Replacement for 400W Metal Halide</b>																				
ED37	E39	S	VBU	360	11.50	7.00	40053	MVR360/VBU/WM/XHO	M59	6		20000	37000	24000	4200	65	Extra High Output	↔	32, 49	121
		S	VBU	360	11.50	7.00	40055	MVR360/C/VBUWMXHO	M59	6		20000	35000	23000	4000	70	Extra High Output	↔	32, 49	121
<b>400 Watts</b>																				
ED37	E39	S	VBU	400	11.50	7.00	49657	MVR400/VBU/HO	M59	6		20000	41000	26500	4000	65	High Output		49	121
		S	VBD	400	11.50	7.00	49655	MVR400/VBD	M59	6		20000	41000	26500	4000	65	Clear		49	121
		S	VBU	400	11.50	7.00	20931	MVR400SP30VBU/HO	M59	6		20000	34000	20400	3200	70	RE730 Phosphor Coating		49	121
		S	VBU	400	11.50	7.00	13923	MVR400/VBU/XHO	M59	6		20000	43000	28000	4000	65	Extra High Output		49	121
ED28	E39	S	VBU	400	11.50	7.00	13924	MVR400/C/VBU/XHO	M59	6		20000	42000	27000	3700	70	Extra High Output		49	121
		E	VBU	400	8.31	5.00	40335	MVR400/VBUED28HO	M59	12		20000	41000	26500	4000	65	Clear, Compact		49	121
BT37	E39	E	HOR	400	8.25	5.00	40201	MVR400/HOR/BT28	M59	12		20000	37000	22000	4200	65	Compact, Horizontal		49	117
		E	HOR	400	11.50	7.00	26218	MVR400/HOR/MOG	M59	6		20000	38000	22500	4200	65	Clear		49	117
BT37	E39	E	HOR	400	11.50	7.00	26219	MVR400/C/HOR/M												

# High Intensity Discharge Lamps

Bulb Shape	Base	LET	OP	Watts	MOL (in)	LCL (in)	Order Code	Description	ANSI Ballast Type	Case Qty	CBCP	Rated Life (hrs)	Initial Lumens	Mean Lumens	Color Temp K	CRI	Additional Information	Reduced Watts/High Color Rendering	Footnotes	Warning and Caution Notices
<b>Protected Multi-Vapor® Metal Halide Lamps</b>																				
<b>32 Watts</b>																				
ED17	E26	O	VBD	32	5.43	3.43	12651	MXR32/C/VBD/O	M100	6		10000	2400	1700	3200	70	Coated, Protected			119
		O	VBU	32	5.43	3.43	16469	MXR32/C/VBU/O	M100	6		10000	2400	1700	3200	70	Coated, Protected			119
<b>50 Watts</b>																				
ED17	E26	O	U	50	5.43	3.43	45670	MXR50/U/MED/O	M110	6		10000	3400	1700	3500	70	Clear, Protected			120
		O	U	50	5.43	3.43	45671	MXR50/C/U/MED/O	M110	6		10000	3200	1500	3500	70	Coated, Protected			120
<b>70 Watts</b>																				
ED17	E26	O	U	70	5.43	3.43	12377	MXR70/U/MED/O	M98	6		12000	5500	3500	3200	70	Clear, Protected			120
		O	U	70	5.43	3.43	12577	MXR70/C/U/MED/O	M98	6		15000	5300	3300	3200	70	Coated, Protected			120
<b>100 Watts</b>																				
ED17	E26	O	U	100	5.43	3.43	12381	MXR100/U/MED/O	M90	6		15000	9000	6200	3200	70	Clear, Protected			120
		O	U	100	5.43	3.43	12579	MXR100/C/U/MED/O	M90	6		15000	8500	5900	3200	70	Coated, Protected			120
<b>150 Watts</b>																				
ED17	E26	O	U	150	5.43	3.43	45683	MXR150/U/MED/O	M102	6		15000	12500	8600	3500	70	Clear, Protected			120
		O	U	150	5.43	3.43	45688	MXR150/C/U/MED/O	M102	6		15000	12000	8300	3500	70	Coated, Protected			120
<b>175 Watts</b>																				
BT28	EX39	O	VBU	175	8.25	5.00	49470	MPR175/VBU/O	M57	6		10000	14400	10200	4000	65	Clear, Protected			119
		O	VBU	175	8.25	5.00	11649	MPR175/C/VBU/O	M57	6		10000	12800	7800	3800	70	Coated, Protected			119
<b>250 Watts</b>																				
BT28	EX39	O	VBU	250	8.25	5.00	49471	MPR250/VBU/O	M58	6		10000	23000	17000	4000	65	Clear, Protected			119
		O	VBU	250	8.25	5.00	11650	MPR250/C/VBU/O	M58	6		10000	20500	29500	3800	70	Coated, Protected			119
<b>320 Watts</b>																				
ED37	EX39	O	VBU	320	11.50	7.00	46275	MPR320/VBU/XHOPA	M132	6		20000	32000	22500	4000	65	Clear, Protected			120
		O	VBU	320	11.50	7.00	46276	MPR320C/VBUXHOPA	M132/M154	6		20000	30500	21500	3700	70	Coated, Protected			120
ED28	EX39	O	VBU	320	8.25	5.00	19609	MPR320C/PA/ED28	M132	12		20000	30600	22500	3700	70	Coated, Protected		43	120
<b>350 Watts</b>																				
ED37	EX39	O	VBU	350	11.50	7.00	10202	MPR350/VBU/PA	M131	6		20000	35200	24600	3700	65	Clear, Protected		43	120
		O	VBU	350	11.50	7.00	48824	MPR350C/VBU/PA	M131	6		20000	33400	23500	3700	70	Coated, Protected		43	120
		O	VBU	350	11.50	7.00	48825	MPR350C/VBU3K/PA	M131	6		20000	33400	23500	3200	70	Coated, Protected		43	120
<b>360 Watts - Watt-Miser® Energy-Saving Replacement for 400W Metal Halide</b>																				
ED37	EX39	O	VBU	360	11.50	7.00	40056	MPR360/VBUWM/HO/O	M59	6		20000	36000	23500	4000	65	Clear, Protected		32, 49	119
		O	VBU	360	11.50	7.00	11685	MPR360C/VBUWMHO/O	M59	6		20000	35000	22500	3700	70	Coated, Protected		32, 49	119
<b>400 Watts</b>																				
ED37	EX39	O	VBU	400	11.50	7.00	18708	MPR400/VBU/HO/O	M59	6		20000	40000	26000	3400	65	Clear, Protected		49	119
		O	VBU	400	11.50	7.00	13582	MPR400C/VBU/HO/O	M59	6		20000	38000	25000	3200	70	Coated, Protected		49	119
		O	VBU	400	11.50	7.00	46273	MPR400/VBU/XHOPA	M135/M155	6		20000	42000	29500	4000	65	Clear, Protected		43, 49	120
		O	VBU	400	11.50	7.00	46274	MPR400C/VBUXHOPA	M135/M155	6		20000	40000	28000	3700	70	Coated, Protected		43, 49	120
<b>1000 Watts</b>																				
BT56	EX39	O	VBU	1000	15.37	9.50	41433	MPR100/VBU/O	M47	6		12000	107000	85500H/25500V	3500	65	Clear, Protected		49	119
<b>Chromafit™ Multi-Vapor® Metal Halide Lamps (HPS Retrofit Lamps)</b>																				
<b>250 Watts</b>																				
ED28	E39	E	VBU	250	8.25	5.75	12762	MVR250/VBU/R	S50	12		10000	18500	13900	4500	65	Clear, HPS Retrofit		50	116
		E	VBU	250	8.25	5.75	12769	MVR250C/VBU/R	S50	12		10000	18000	13000	4000	70	Coated, HPS Retrofit		50	116
<b>1000 Watts</b>																				
ED28	E39	E	U	400	8.31	5.00	26851	MVR400/U/ED28/R	S51	12		15000H/20000V	33100H/36000V	20200H/22000V	4000	65	Clear, Compact, HPS Retrofit		49, 50	116
ED37	E39	S	VBU	400	11.50	5.75	12770	MVR400/VBU/R	S51	6		20000	37600	22600	4500	65	Clear, HPS Retrofit		49, 50	122
		S	VBU	400	11.50	5.75	12772	MVR400C/VBU/R	S51	6		20000	35700	21400	4000	70	Coated, HPS Retrofit		49, 50	122
<b>I-Line Multi-Vapor® Metal Halide Lamps (Mercury Retrofit Lamps)</b>																				
<b>325 Watts</b>																				
ED37	E39	S	U	325	11.50	7.00	10687	MVR325/U/U/WM	H33	6		10000H/20000V	25800H/28000V	12200H/28000V	4000	65	Clear, Watt-Miser®	↔	49	121
ED37	E39	S	U	325	11.50	7.00	10688	MVR325C/U/U/WM	H33	6		10000H/20000V	24200H/26300V	11800H/12900V	3700	70	Coated, Watt-Miser®	↔	49	121
<b>400 Watts</b>																				
ED37	E39	S	U	400	11.50	7.00	43817	MVR400/U	H33/M59	6		10000H/15000V	33100H/36000V	22100H/24000V	4000	65	Clear, 400W Mercury Retrofit		49	121
		S	U	400	11.50	7.00	43818	MVR400C/U	H33/M59	6		10000H/15000V	32200H/35000V	19300H/21000V	3700	70	Clear, 400W Mercury Retrofit		49	121

For the most up-to-date product information, see [www.gelighting.com](http://www.gelighting.com). To convert inches to millimeters, multiply by 25.4. All footnotes, warning and caution notices found at the end of this section (page 3-20).

Bulb Shape	Base	LET	OP	Watts	MOL (in)	LCL (in)	Order Code	Description	ANSI Ballast Type	Case Qty	CBCP	Rated Life (hrs)	Initial Lumens	Mean Lumens	Color Temp K	CRI	Additional Information	Reduced Watts/High Color Rendering	Footnotes	Warning and Caution Notices
<b>I-Line Multi-Vapor® Metal Halide Lamps (Mercury Retrofit Lamps) (continued)</b>																				
<b>950 Watts Energy-Saving Replacement for 1000W Mercury</b>																				
BT56	E39	S	VBU	950	15.06	9.50	39097	MVR950/VBU	H36/M47	6		12000	100000	62900	3800	65	Coated, Retrofit Watt-Miser®	↔	49	121
<b>Saf-T-Gard® Self-Extinguishing Multi-Vapor® Lamps</b>																				
<b>400 Watts</b>																				
ED37	E39	S	U	400	11.50	7.00	11146	MVT400/U	H33/M59	6		10000H/15000V	33100H/36000V	22100H/23500V	4000	65	Clear, Retrofit		49	123
		S	U	400	11.50	7.00	11119	MVT400C/U	H33/M59	6		10000H/15000V	32200H/35000V	19300H/23000V	3700	70	Coated, Retrofit		49	123
		S	VBU	400	11.50	7.00	11144	MVT400/VBU	M59	6		20000	41000	26500	4000	65	Clear		49	123
		S	VBU	400	11.50	7.00	11145	MVT400C/VBU	M59	6		20000	41000	26500	3700	70	Coated		49	123
<b>Arcstream® Metal Halide Lamps</b>																				
<b>70 Watts</b>																				
T6	R7s	E	HOR	70	4.68		34530	ARC70/TD/UVC/730	M85	12		6000	6000	4800	3000	75	Clear			103
		E	HOR	70	4.68		34536	ARC70/TD/UVC/743	M85	12		6000	6000	4800	4300	75	Clear			103
<b>150 Watts</b>																				
T7	R7s	E	HOR	150	5.37		34527	ARC150/TD/730R7S	M81	12		6000	13000	11000	3000	75	Clear			103
		E	HOR	150	5.37		34535	ARC150/TD/742R7S	M81	12		6000	12000	10000	4200	75	Clear			103
T6	G12	E	U	150	3.00	2.25	21053	ARC150T/U/830G12	M81	10		6000	12000	9500	3000	80	Clear			102
		E	U	150	3.00	2.25	21054	ARC150T/U/840G12	M81	10		6000	11500	10500	4000	80	Clear			102
T7	GY9.5	E	BDH	150	1.62	1.12	34813	CSS150/CAP/50	M81	10		1000	10000	8000	5000	80	Clear, Disco Lamp			102
<b>250 Watts</b>																				
T15	E39	E	HOR	250	8.37	5.62	26683	ARC250T/H960/E39	M80	12		10000	19000	13300	6000	90	Clear			101
<b>Lucalox® High Pressure Sodium Lamps</b>																				
<b>200 Watts</b>																				
ED18	E39	O	U	200	9.75	5.75	44206	LU200	S66	12		24000+	22000	19800	2100	22	Clear			111
<b>250 Watts</b>																				
ED18	E39	O	U	250	9.75	5.75	44047	LU250	S50	12		24000+	28000	25200	2100	22	Clear			111
		O	U	250	9.75	5.75	26430	LU250/CP	S50	4		24000+	28000	25200	2100	22	Clear, Consumer Pack			111
		O	U	250	9.00	5.00	44051	LU250/D	S50	12		24000+	26000	23400	2100	22	Diffuse			111
<b>310 Watts</b>																				
ED18	E39	O	U	310	9.75	5.75	44053	LU310	S67	12		24000+	37000	33300	2100	22	Clear			111
<b>400 Watts</b>																				
ED18	E39	O	U	400	9.75	5.75	44054	LU400	S51	12		24000+	51000	45000	2100	22	Clear			111
		O	U	400	9.75	5.75	26431	LU400/CP	S51	4		24000+	51000							

# High Intensity Discharge Lamps

Bulb Shape	Base	LET	OP	Watts	MOL (in)	LCL (in)	Order Code	Description	ANSI Ballast Type	Case Qty	CBCP	Rated Life (hrs)	Initial Lumens	Mean Lumens	Color Temp K	CRI	Additional Information	Reduced Watts/High Color Rendering	Footnotes	Warning and Caution Notices
<b>Ecolum® High Pressure Sodium Lamps (TCLP Compliant) (continued)</b>																				
<b>70 Watts</b>																				
B17	E26	O	U	70	5.43	3.43	11339	LU70/MED/ECO	S62	6		24000+	6400	5450	1900	22	TCLP Compliant			111
		O	U	70	5.43	3.43	26422	LU70/MED/CP	S62	4		24000+	6400	5450	1900	22	TCLP Compliant, Consumer Pack			111
		O	U	70	5.43	3.43	11340	LU70/D/MED/ECO	S62	6		24000+	5950	5050	1900	22	TCLP Compliant, Diffuse			111
ED23.5	E39	O	U	70	7.75	5.00	85368	LU70/H/ECO	S62	12		24000+	6400	5450	1900	22	TCLP Compliant			111
		O	U	70	7.75	5.00	26426	LU70/CP	S62	4		24000+	6400	5450	1900	22	TCLP Compliant, Consumer Pack			111
		O	U	70	7.75	5.00	72605	LU70/D/H/ECO	S62	12		24000+	5950	5050	1900	22	TCLP Compliant, Diffuse			111
<b>100 Watts</b>																				
B17	E26	O	U	100	5.50	3.43	13250	LU100/MED/ECO	S54	6		24000+	9500	8550	2000	22	TCLP Compliant			111
		O	U	100	5.50	3.43	26423	LU100/MED/CP	S54	4		24000+	9500	8550	2000	22	TCLP Compliant, Consumer Pack			111
		O	U	100	5.50	3.43	13251	LU100/D/MED/ECO	S54	6		24000+	8800	7920	2000	22	TCLP Compliant, Diffuse			111
ED23.5	E39	O	U	100	7.75	5.00	85369	LU100/H/ECO	S54	12		24000+	9500	8550	2000	22	TCLP Compliant			111
		O	U	100	7.75	5.00	26427	LU100/CP	S54	4		24000+	9500	8550	2000	22	TCLP Compliant, Consumer Pack			111
		O	U	100	7.75	5.00	72606	LU100/D/H/ECO	S54	12		24000+	8800	7920	2000	22	TCLP Compliant, Diffuse			111
<b>150 Watts</b>																				
B17	E26	O	U	100	5.75	3.50	13252	LU150/MED/ECO	S55	6		24000+	16000	14400	2000	22	TCLP Compliant			111
		O	U	100	5.75	3.50	26424	LU150/MED/CP	S55	4		24000+	16000	14400	2000	22	TCLP Compliant, Consumer Pack			111
		O	U	100	5.75	3.50	13253	LU150/D/MED/ECO	S55	6		24000+	15000	13500	2000	22	TCLP Compliant, Diffuse			111
ED23.5	E39	O	U	150	7.75	5.00	85371	LU150/55/H/ECO	S55	12		24000+	16000	14400	2000	22	TCLP Compliant			111
		O	U	150	7.75	5.00	26429	LU150/55/CP	S55	4		24000+	16000	14400	2000	22	TCLP Compliant, Consumer Pack			111
		O	U	150	7.75	5.00	85380	LU150/55/D/H/ECO	S55	12		24000+	15000	13500	2000	22	TCLP Compliant, Diffuse			111
<b>200 Watts</b>																				
ED18	E39	O	U	200	9.75	5.75	85372	LU200/H/ECO	S66	12		24000+	22000	19800	2100	22	TCLP Compliant			111
<b>250 Watts</b>																				
ED18	E39	O	U	250	9.75	5.75	85377	LU250/H/ECO	S50	12		24000+	28000	25200	2100	22	TCLP Compliant			111
		O	U	250	9.75	5.75	85381	LU250/D/H/ECO	S50	12		24000+	26000	23400	2100	22	TCLP Compliant, Diffuse			111
<b>400 Watts</b>																				
ED18	E39	O	U	400	9.75	5.75	85379	LU400/H/ECO	S51	12		24000+	51000	45000	2100	22	TCLP Compliant			111
<b>1000 Watts</b>																				
E25	E39	O	U	1000	15.06	8.75	44058	LU1000/ECO	S52	6		24000+	130000	117000	2100	22	TCLP Compliant		49	111
<b>Standby Longlife Lucalox® Lamps</b>																				
<b>70 Watts</b>																				
ED23.5	E39	O	U	70	7.75	5.00	19264	LU70/SBY/XL	S62	12		40000	6400	5050	2000	22	Clear, Standby Longlife, Dual Arc Tube			111
<b>100 Watts</b>																				
ED23.5	E39	O	U	100	7.75	5.00	19265	LU100/SBY/XL	S54	12		40000	9500	8190	2000	22	Clear, Standby Longlife, Dual Arc Tube			111
<b>150 Watts</b>																				
ED23.5	E39	O	U	150	7.75	5.00	19266	LU150/55/SBY/XL	S55	12		40000	16000	14000	2000	22	Clear, Standby Longlife, Dual Arc Tube			111
<b>200 Watts</b>																				
ED18	E39	O	U	200	9.75	5.75	23431	LU200/SBY/XL	S66	12		40000	215000	18150	2000	22	Clear, Standby Longlife, Dual Arc Tube			111
<b>250 Watts</b>																				
ED18	E39	O	U	250	9.75	5.75	19270	LU250/SBY/XL	S50	12		40000	27500	24750	2000	22	Clear, Standby Longlife, Dual Arc Tube			111
<b>400 Watts</b>																				
ED18	E39	O	U	400	9.75	5.75	19272	LU400/SBY/XL	S51	12		40000	500000	45000	2000	22	Clear, Standby Longlife, Dual Arc Tube		49	111

For the most up-to-date product information, see [www.gelighting.com](http://www.gelighting.com). To convert inches to millimeters, multiply by 25.4. All footnotes, warning and caution notices found at the end of this section (page 3-20).

Bulb Shape	Base	LET	OP	Watts	MOL (in)	LCL (in)	Order Code	Description	ANSI Ballast Type	Case Qty	CBCP	Rated Life (hrs)	Initial Lumens	Mean Lumens	Color Temp K	CRI	Additional Information	Reduced Watts/High Color Rendering	Footnotes	Warning and Caution Notices
<b>Standby Longlife Lucalox® Lamps (continued)</b>																				
<b>1000 Watts</b>																				
E25	E39	O	U	1000	15.06	8.75	27185	LU1000/SBY/XL	S52	6		40000	127000	115000	2100	22	Clear, Standby Longlife, Dual Arc Tube		49	111
<b>Ecolum® NC Non-Cycling High Pressure Sodium Lamps (TCLP Compliant)</b>																				
<b>70 Watts</b>																				
ED23.5	E39	O	U	70	7.75	5.00	14672	LU70/ECO/NC	S62	12		30000	6300	5670	1900	23	Clear, Non-Cycling			111
<b>100 Watts</b>																				
ED23.5	E39	O	U	100	7.75	5.00	14673	LU100/ECO/NC	S54	12		30000	10500	9450	2000	23	Clear, Non-Cycling			111
<b>150 Watts</b>																				
ED23.5	E39	O	U	150	7.75	5.00	40390	LU150/55/ECO/NC	S55	12		30000	16000	14400	2000	23	Clear, Non-Cycling			111
<b>200 Watts</b>																				
ED18	E39	O	U	200	9.75	5.75	45059	LU200/ECO/NC	S66	20		30000	22000	19800	2100	22	Clear, Non-Cycling			111
<b>250 Watts</b>																				
ED18	E39	O	U	250	9.75	5.75	14674	LU250/ECO/NC	S50	12		30000	29000	26100	2000	30	Clear, Non-Cycling			111
<b>400 Watts</b>																				
ED18	E39	O	U	400	9.75	5.75	14675	LU400/ECO/NC	S51	12		30000	54000	48600	2100	30	Clear, Non-Cycling			111
<b>Deluxe Lucalox® High Pressure Sodium Lamps</b>																				
<b>70 Watts</b>																				
B17	E26	O	U	70	5.50	3.50	16611	LU70/DX/MED	S62	6		10000	3800	3040	2200	65	Clear, Improved CRI			111
<b>150 Watts</b>																				
B17	E26	O	U	150	5.75	3.50	18094	LU150/DX/MED	S54	6		15000	10500	9135	2200	65	Clear, Improved CRI			111
ED23.5	E39	O	U	150	7.75	5.00	18092	LU150/55/DX	S55	12		15000	10500	9135	2200	65	Clear, Improved CRI			111
<b>250 Watts</b>																				
ED18	E39	O	U	250	9.75	5.75	11785	LU250/DX	S50	12		15000	225000	20700	2200	65	Clear, Improved CRI			111
<b>400 Watts</b>																				
ED28	E39	O	U	400	9.00	5.18	19650	LU400/DX	S51	12		15000	37400	34400	2200	70	Clear, Improved CRI		49	111
<b>E-Z Lux® High Pressure Sodium Lamps (Mercury Retrofit)</b>																				
<b>150 Watts</b>																				
ED28	E39	O	U	150	9.00	5.00	49943	LUH150/EZ	H39/ S63	12		13000	12500	12000	1900	22	Clear, Energy-Saving Retrofit for 250W Mercury	↔	46	111
<b>215 Watts</b>																				
BT28	E39	O	U	215	8.30	5.00	49939	LUH215/EZ	H37/ S65	12		16000	20000	17000	2000	20	Clear, Energy-Saving Retrofit for 250W Mercury	↔	47	111
<b>360 Watts</b>																				
BT37	E39	O	U	360	11.31	7.12	18012	LUH360/EZ	H33/ S64	6		24000	45000	40500	2100	25	Clear, Energy-Saving Retrofit for 250W Mercury	↔	48,49	111
<b>Mercury Lamps</b>																				
<b>40/50 Watts</b>																				
B17	E26	O	U	50	5.12	3.12	12460	HR40/50DX45-46	H45	5		6000	1575H/1140V	910H/1250V	3900	50	40W on H45 Ballast, 50W on H46 Ballast, Deluxe White			113
<b>75 Watts</b>																				
B17	E26	O	U	75	5.43	3.50	12461	HR75DX43	H43	5		16000	2700	2250	3900	50	Deluxe White			113
<b>100 Watts</b>																				
A23.5	E26	O	U	100	5.43	3.50	12467	HR100DX38/A23	H38	5		18000	4000	2600	3800	50	Deluxe White			113
B17	E26	O	U	100	5.43	3.50	17113	HR100DX38/MED	H38	5		18000	4000	2600	3900	50	Deluxe White			113
ED23.5	E39	O	U	100	7.50	5.00	12471	HR100A38	H38	5		24000+	3850	2500	5700	15	Clear			113
		O	U	100	7.50	5.00	22575	HR100DX38	H38	12		24000+	4000	2600	3900	50	Deluxe White			113
		O	U	100	7.50	5.00	26437	HR100DX38/CP	H38	4		24000+	4000	2600	3900	50	Deluxe White, Consumer Pack			113
R40	E26	O	U	100	7.00		36238	HR100RFL38	H38	12		24000+	2450	2000	5700	15	Reflector Flood, Beam Spread			113
		O	U	100	7.00		36495	HR100RDXFL38	H38	12		24000+	2450	2050	3900	50	Deluxe White, Reflector WFL, Beam Spread			113
<b>175 Watts</b>																				
ED28	E39	O	U	175	8.25	5.00	24048	HR175A39	H39	12		24000	7850	6830	5700	15	Clear			113
		O	U	175	8.25	5.00	26440	HR175A39/CP	H39	4		24000	7850	6830	5700	15	Clear, Consumer Pack			113
		O	U	175	8.25	5.00	24062	HR175DX39	H39	12		24000	7800	6800	3900	50	Deluxe White			113
		O	U	175	8.25	5.00														

# High Intensity Discharge Lamps

Bulb Shape	Base	LET	OP	Watts	MOL (in)	LCL (in)	Order Code	Description	ANSI Ballast Type	Case Qty	CBCP	Rated Life (hrs)	Initial Lumens	Mean Lumens	Color Temp K	CRI	Additional Information	Reduced Watts/ High Color Rendering	Footnotes	Warning and Caution Notices		
<b>Mercury Lamps (continued)</b>																						
<b>175 Watts (continued)</b>																						
R40	E26	O	U	175	7.00		33026	HR175RDXFL39	H39	12		24000+	5700	4350	3900	50	Deluxe White, Reflector WFL, Beam Spread			113		
<b>250 Watts</b>																						
ED28	E39	O	U	250	8.25	5.00	24068	HR250A37	H37	12		24000	11000	8250	5700	15	Clear			113		
		O	U	250	8.25	5.00	32127	HR250DX37	H37	12		24000	11200	8400	3900	50	Deluxe White			113		
<b>400 Watts</b>																						
BT37	E39	O	U	400	11.31	7.00	32313	HR400DX33/BT	H33	6		24000+	22600	14400	3900	50	Deluxe White			113		
ED37	E39	O	U	400	11.31	7.00	23974	HR400A33	H33	6		24000	21000	13400	5700	15	Clear			113		
		O	U	400	11.31	7.00	23998	HR400DX33	H33	6		24000	22600	14400	3900	50	Deluxe White			113		
R52	E39	O	U	400	11.75		33879	HR400RDX33	H33	6		24000+	20800	13400	3900	50	Reflector, Deluxe White, 160 Beam Spread			113		
R60	E39	O	U	400	10.12		33938	HR400RDXFL33	H33	6		24000+	15500	8950	3900	50	Reflector WFL, Deluxe White, Clear Face, 110 Beam			113		
<b>1000 Watts</b>																						
BT56	E39	O	U	1000	15.06	9.50	24171	HR1000A36	H36	6		24000+	57000	28500	5700	15	Clear		49	113		
		O	U	1000	15.06	9.50	24191	HR1000DX36	H36	6		24000+	58000	29000	3900	50	Deluxe White		49	113		
		O	U	1000	15.06	9.37	32733	HR1000DX34	H34	6		16000	58300	29200	3900	50	Deluxe White		28,49	113		
<b>Saf-T-Gard® Mercury Lamps</b>																						
<b>175 Watts</b>																						
ED28	E39	O	U	175	8.25	5.00	43391	HT175DX39	H39	12		16000	7800	6800	3900	50	Deluxe White			114		
<b>400 Watts</b>																						
ED37	E39	O	U	400	11.31	7.00	43363	HT400DX33	H33	6		24000	22600	14400	3900	50	Deluxe White		49	114		
<b>E-Z Merc® Self-Ballasted Lamps (Incandescent Retrofit)</b>																						
<b>160 Watts</b>																						
ED24	E26	O	U	160	7.00	4.50	45178	HSB160/M	B87	24		12000	2300	1600	3900	50	Deluxe White		9	115		
<b>250 Watts</b>																						
ED28	E26	O	U	250	8.50	5.18	45174	HSB250M	B94	12		12000	5000	3750	3900	50	Deluxe White		9	115		
ED28	E39	O	U	250	8.50	5.18	45176	HSB250	B94	12		12000	5000	3750	3900	50	Deluxe White		9	115		
<b>450 Watts</b>																						
BT37	E39	O	U	450		7.37	40122	HSB450	B75	6		16000	9100	8280	3900	50	Deluxe White		9,49	115		
<b>750 Watts</b>																						
R57	E39	O	U	750	12.75	8.37	44012	HSB750R/120	B78	6		16000	14000	11200	3900	50	Deluxe White, Reflector Flood, 120V, 130 Beam		9,49	115		
<b>Export Lamps</b>																						
<b>Metal Halide</b>																						
ED28	E40	E	U	175	8.25	5.00	47762	MVR175/U/40	M57	12		6000H/1000V	11700H/13600V	7400H/8800V	4000	65	Clear			117		
		E	U	175	8.25	5.00	47763	MVR175/C/U/40	M57	12		6000H/1000V	11900H/12900V	7900H/8400V	3900	70	Coated			117		
		E	U	175	8.25	5.00	44542	MVR250/U/40	M58	12		6000H/1000V	19100H/20800V	12400H/13500V	4200	65	Clear			117		
		E	U	250	8.25	5.00	44543	MVR250/C/U/40	M58	12		6000H/1000V	18200H/19800V	11600H/13000V	3900	70	Coated			117		
		ED37	E40	S	U	400	11.50	7.00	43907	MVR400/U/40	M59	6		15000H/20000V	33100H/36000V	22100H/23500V	4000	65	Clear		49	121
				S	U	400	11.50	7.00	43908	MVR400/C/U/40	M59	6		15000H/20000V	32200H/35000V	19300H/23000V	3700	70	Coated		49	121
S	VBU			400	11.50	7.00	49860	MVR400/VBU/40	M59	6		20000	41000	26500	4000	65	Clear, Vertical Base Up		49	121		
S	VBU			400	11.50	7.00	49857	MVR400/C/VBU/40	M59	6		20000	41000	25000	3700	70	Coated, Vertical Base Up		49	121		
		O	VBU	400	11.50	7.00	27738	MPR400C/VBU/O/40	M59	6		20000	38000	26000	3200	70	Coated, Vertical Base Up, Protected		49	119		
		O	VBU	400	11.50	7.00	18709	MPR400/VBU/O/40	M59	6		20000	40000	26000	3400	65	Clear, Vertical Base Up, Protected		49	119		
BT56	E40	S	U	1000	15.37	9.50	41828	MVR1000/U/40	M47	6		11000H/15000V	1002800H/108000V	79000H/86000V	4000	65	Clear		49	121		
		S	U	1000	15.37	9.50	41829	MVR1000/C/U/40	M47	6		11000H/15000V	96600H/10500V	73000H/80000V	3700	65	Coated		49	121		
<b>Lucalox® High Pressure Sodium</b>																						
ED23.5	E40	O	U	150	7.75	5.00	44044	LU150/55/40	S55	12		24000+	16000	14400	2000	22	Clear			111		
ED18	E40	O	U	250	9.75	5.75	44048	LU250/40	S50	12		24000+	28000	25200	2100	22	Clear			111		
		O	U	400	9.00	5.75	44055	LU400/40	S51	12		24000+	51000	45000	2100	22	Clear			111		
E25	E40	O	U	1,000	15.06	8.75	44059	LU1000/40	S52	6		24000+	130000	117000	2100	22	Clear			111		

For the most up-to-date product information, see [www.gelighting.com](http://www.gelighting.com). To convert inches to millimeters, multiply by 25.4. All footnotes, warning and caution notices found at the end of this section (page 3-20).

## General Information

### Fixture Requirements – Lamp Enclosure type

HID lamps have fixture requirements that must be followed. The following three codes identify the appropriate fixture for a particular lamp. Lamps having an “O” code can be operated in an “Open or Enclosed” fixture. Lamps with a “S” code can be used in open fixtures only if operated in a vertical ±15° burn position. Lamps in all other burn positions must be suitably enclosed.

O = Open or Enclosed Fixtures

E = Enclosed Fixtures Only

S = Lamps operated in a vertical position (Base Up or Down), ±15°, can be used in an open fixture. Lamps burned in any other orientation must be used in “enclosed fixtures only.”

**Use in Enclosed Fixtures.** “Enclosed” fixture means a fixture suitably enclosed and designed to contain fragments of hot quartz or glass (up to 1100°C) per UL Standard #1598 (if in doubt, contact your fixture manufacturer).

**Use In Open Fixtures.** For lamps operated in the vertical position ±15° that are not designated “Enclosed Fixtures Only,” lamp may be used in an open or enclosed lighting fixture depending upon the application and operating environment. For example, if the lamp is located near combustible material or in an area which is unoccupied for extended periods, an enclosed fixture which can contain fragments of hot quartz or glass is recommended. For more information, contact your fixture manufacturer.

### Protection of Bulbs from Moisture

Outer bulbs of HID lamps are made of heat-resistant glass, designed to have strength and thermal-shock-resistant characteristics suitable for normal applications in typical luminaries. However, shielding of lamps must be provided to avoid bulb breakage that could result from direct contact with liquids (such as water) during operation.

### Rated Life

Values are based on laboratory tests of a large number of representative lamps under controlled conditions, including operation at 10 hours per start on ballasts having specified electrical characteristics. Individual lamps or groups of lamps may, of course, vary from the Rated Life shown. Lamp operating conditions can also affect life. Where Rated Life is less than 24,000 hours, it is a MEDIAN value of life expectancy; that is, the total operating time at which, under normal operating conditions, 50% of any large group of initially installed lamps is expected to be still burning. Where Rated Life is 24,000+ hours, 67% of lamps are expected to be still burning at 24,000 hours. For cost-of-light calculations involving these lamps, if an estimated operating time is required at which 50% of the lamps will still be burning, a value of 28,500 hours is suggested. At burning cycles shorter than 10 hours per start, the median life will be shortened as follows:

5 hrs/start: approx. life 75% of rating

2-1/2 hrs/start: approx. life 56% of rating

1-1/4 hrs/start: approx. life 42% of rating

### Lumens – Lumens listed are reference lumens

Rated average lamp lumens are obtained under controlled laboratory conditions in a prescribed burning position. **Initial Reference Lumens** refer to the lamp lumen output after 100-hours burning. **Mean Reference Lumens** refer to the lamp lumen output at the mean lumen point during lamp life. The mean lumen point occurs at 50% rated life for HPS and mercury lamps, and at 40% rated life for metal halide lamps. Lamp performance on typical systems under typical service conditions will vary from the reference lumen ratings.

High Intensity Discharge lighting systems are subject to a wide range of variations which may affect final lighting levels. As a result, lamp performance on actual systems may vary due to lamp orientation, ambient temperatures, ballast variations, line voltage and other

For the most up-to-date product information, see [www.gelighting.com](http://www.gelighting.com).

reasons. Care must be taken when choosing a system to consider how these changes can affect your light levels both initially and at the mean lumen point.

### Ballasts

HID lamps (except E-Z-Merc®) require auxiliary ballast equipment designed to produce proper electrical values. Actual lamp watts may vary depending on ballast characteristics. For total system watts, add nominal ballast watts.

All Lucalox®, Mercury, and Metal Halide lamps (except I-Line) will start at ambient temperatures of -22°F (-30°C). I-Line Multi-Vapor® will start at ambient temperatures of 5°F (-15°C) when used on approved mercury ballasts.

### Start Characteristics

Full light output does not occur immediately when power is applied. Instead, there is a time delay for the lamp to reach 90% total light output. The starting delay for High Pressure Sodium is 3-4 minutes, for Metal Halide 2-5 minutes, and for Mercury 5-7 minutes.

### Restart Characteristics

With a power interruption of a half cycle or more, the arc will extinguish. When power is immediately reapplied, full light output does not occur immediately. For HPS lamps there is a delay of 1 minute to reach 90% total light output; however, Lucalox® LU1000 requires 2 minutes and E-Z Lux® lamps require 3 minutes to reach 90% total light output. For most Metal Halide lamps, including CMH®, when the power is immediately reapplied, there will be a delay of 10 to 17 minutes before the lamps reach the 90% light output level. PulseArc® lamps restrike in <4 minutes. The restart delay for mercury lamps is 3 to 6 minutes to reach 90% total light output.

### Operating Positions and Codes

Mercury and High Pressure Sodium lamps may be operated in any burn position and will still maintain their rated performance specifications. Metal Halide and Low Pressure Sodium lamps, however, are optimized for performance in specific burn positions, or may be restricted to certain burn positions for safety reasons.

U = Universal burning position

HBU = Horizontal -15° to Base Up

HBD = Horizontal +15° to Base Down

HOR = Horizontal ±15°

HOR PA = ±75°

HOR ±60° = applies to MVR 1650

H45 = Horizontal to ±45° only

VBU = Vertical Base Up ±15°

VBD = Vertical Base Down ±15°

If no special burn position is noted, the burn position is universal.

### HID Color

The color temperature and CRI listed in the tabular data are for reference purposes only. All high intensity discharge lamps exhibit some degree of lamp-to-lamp color variation and shift over life. These characteristics can be increased based on choice of fixture, ballast, burning position, and ambient conditions. Color variation can be greater than normal during the initial 100 hours of burning. Where color consistency is important, consider using ConstantColor® CMH® for better performance. Contact your local GE Lighting representative for more information.

### Export Base Lamps (/27 and /40)

Export only lamps have a non-domestic (non-U.S.) base and are not intended for use in the United States due to potential shock hazard. The lamps are identified by “/27” or “/40” at the end of the lamp description and comply with electrical characteristics defined by IEC standards.

# High Intensity Discharge Lamps

## Operating Notes

### CMH® Chromafit™ Metal Halide Lamps

Use in enclosed luminaire with front cover made of glass, capable of containing the fragments of a lamp should it shatter, to avoid risk of fire. Do not use with Polymeric Lens.

### E-Z Lux® Lamps

These high pressure sodium lamps should be operated only on certain mercury ballasts, as indicated below.

LUH110/EZ: use only with the following types of 125-watt mercury ballasts: high-reactance lag-type autotransformers or 220-volt or greater reactors.

LUH150/EZ: use only with the following types of H39 175-watt mercury ballasts: high-reactance lag-type autotransformers or 240-volt and 277-volt reactors. Do not use with CW (lead-type) or CWA ballasts.

LUH215/EZ: use only with the following types of H37 250-watt mercury ballasts: high reactance lag-type autotransformers or 240-volt and 277-volt reactors. Do not use with CW (lead-type) or CWA ballasts.

LUH360/EZ: use only with the following types of H33 400-watt mercury ballasts: high-reactance lag-type autotransformers, reactors, CWA auto regulators or CW regulators.

## Dimming

High Wattage CMH® lamps may be dimmed to 50% of full rated wattage. With dimming, the color shifts to a cooler (higher Kelvin) temperature and CRI decreases. The dimming of 20-150W CMH® lamps is not normally recommended. Large power reductions significantly alter the thermal characteristics of the lamp resulting in color shift. Quartz metal halide and mercury vapor lamps may be dimmed to 50% of full rated wattage. High pressure sodium lamps

### MXR32 Metal Halide Lamp and Electronic Ballast

MXR32 lamps must be operated on GE's special, high-power-factor electronic ballast, HAL32/120. Outside dimensions for the ballast are 9-1/4" long, 3-1/8" wide and 1-3/4" high.

### Saf-T-Gard® Multi-Vapor® and Saf-T-Gard® Mercury Lamps

Caution: If the outer glass envelope of a Saf-T-Gard® lamp is broken, the arc tube will self-extinguish, but the supporting structure will still be electrically connected. Be sure power is off and the lamp has cooled before removing the lamp to avoid possible electrical shock from contact with the arc tube support and to avoid risk of burn from the hot arc tube.

### Arcstream® Metal Halide Lamps

Arcstream® tubular-shaped lamps must be used in suitably enclosed fixtures with UV-absorbing cover glass. Enclosed fixtures must be capable of containing fragments of hot quartz or glass (up to 1100°C) in the unusual event of the outer bulb shattering. Also see complete Warning and Caution Notices on metal halide lamps.

may be dimmed to 35%. For all dimming, the lamp must be started in full-power mode and must be operated in that mode for a minimum of fifteen minutes prior to reduced-power operation. Minimum open circuit voltage must meet ANSI requirements at full-power, during power transition, and in the reduced-power mode to prevent premature cycling (see appropriate ANSI lamp documents for specific minimum OCV requirements). Other application guidelines may apply.

## Warning Notices

**THE FOLLOWING WARNING NOTICES MUST BE COMPLIED WITH TO HELP AVOID POSSIBLE LAMP RUPTURE.** General Electric Company will not be responsible for poor lamp performance, personal injury or property damage resulting from failure to follow these instructions.

### HID LAMPS – GENERAL

#### WARNING

Most HID lamps are constructed of an outer bulb with an internal arc tube made of quartz. The arc tube operates under high pressure at very high temperatures—as high as approximately 1100°C. The arc tube and outer bulb may unexpectedly rupture due to internal causes or external factors such as a system failure or misapplication.

An arc tube rupture can burst and shatter the outer glass bulb resulting in the discharge of glass fragments and extremely hot quartz particles (as high as 1100°C). There is a risk of personal injury, property damage, burns and fire.

Some lamps are position-sensitive and must only be operated in specified burning positions (see "Additional Information" column in this catalog) with compatible electrical equipment in the types of fixtures prescribed in "Lamp Enclosure Type" on page 3-22 of this catalog.

In addition to the general warnings above, there are specific warnings for the HID lamp types listed below.

#### Metal Halide Lamps

Fixture lens/diffuser material must be able to contain fragments of hot quartz or glass (up to 1100°C). If you do not know whether your fixture can safely withstand an arc tube rupture, contact your fixture manufacturer.

In continuously operating systems (24 hours/day, 7 days/week), turn lamps off once per week for at least 15 minutes. FAILURE TO COMPLY INCREASES THE RISK OF RUPTURE.

Ceramic metal halide lamps can be operated 24/7.

Relamp fixtures at or before the end of rated life. Beyond rated life, light output diminishes while energy consumption and risk of rupture increase.

### High Pressure Sodium Lamps

This is a vacuum jacket lamp and may implode if broken. As a precaution, wear safety glasses and gloves when installing or removing lamp. High pressure sodium lamps are not position-sensitive and may be operated in any burning position.

### Mercury Lamps

Fixture lens/diffuser material must be able to contain fragments of hot quartz or glass (up to 1100°C). If you do not know whether your fixture can safely withstand an arc tube rupture, contact your fixture manufacturer.

Relamp fixtures at or before the end of rated life. Beyond rated life, light output diminishes while energy consumption and risk of rupture increase.

Mercury lamps are not position-sensitive and may be operated in any burning position.

### Low Pressure Sodium Lamps

These lamps contain sodium which will ignite when exposed to water. If lamps are not disposed of properly, there is a risk of fire in the disposal vessel. Consult GE for disposal instructions.

### Lamp Enclosure Type

Use in Enclosed Fixtures. "Enclosed" fixture means a fixture suitably enclosed and designed to contain fragments of hot quartz or glass (up to 1100°C) in accordance with UL Standard #1598 (if in doubt, contact your fixture manufacturer).

Use In Open Fixtures. For lamps operated in the vertical position ±15° that are not designated "Enclosed Fixtures Only," lamp may be used in an open or enclosed lighting fixture depending upon the application and operating environment. For example, if the lamp is located near combustible material or in an area which is unoccupied for extended periods, an enclosed fixture which can contain fragments of hot quartz or glass is recommended. For more information, contact your fixture manufacturer.

## Footnotes

- 9 Do not use this lamp in fixtures designed for less than rated lamp wattage.
- 14 Life shown is for vertical +15° operation.
- 16 Approximate lumen ratings at 45° burning position: Initial – 145,000. Mean – 124,000.
- 17 Rated life based on 5 or more burning hours per start.
- 28 Use only 1000-watt H12 or H34-type ballasts. Do not use on 1000-watt H36-type ballasts.
- 32 Lamp will run at 400-watts when used on a linear reactor ballast.
- 33 Rated life based on 11 hours per start.
- 38 Requires a non-ANSI designated ballast with a special, add-on metal halide ignitor. Contact your local GE representative for a list of approved ballasts and ignitors.
- 39 UV Control is a quartz material that effectively cuts UVB and UVC radiation.
- 42 Approximate lumen ratings at 45° burning position: Initial – 153,000. Mean – 139,000.
- 43 When operated on a 120 hrs. cycle (minimum), lamp life rating may be extended by up to 50% based on engineering estimates.

- 44 Rated life based on 7 hours per start.
- 45 Use electronic ballast, peak lead ballast, or system which can shut itself off if ballast overheating occurs.
- 46 Use only with the following types of H39 175-watt mercury ballasts: high-reactance lag-type autotransformers or 240-volt and 277-volt reactors. Do not use with CW (lead-type) or CWA ballasts.
- 47 Use only with the following types of H37 250-watt mercury ballasts: high-reactance lag-type autotransformers or 240-volt and 277-volt reactors. Do not use with CW (lead-type) or CWA ballasts.
- 48 Use only with the following types of H33 400-watt mercury ballasts: high-reactance lag-type autotransformers, reactors, CWA auto regulators or CW regulators.
- 49 Not for use with lampholders that have stainless steel center contacts to avoid lamp or lampholder damage due to arcing.
- 50 Not for use on Magnetic-Regulator or Electronic-Regulator ballast systems to avoid ballast overheating.
- 51 Use only with electronic ballast.
- 52 Use only with approved ballast.

## Important Notice

In accordance to Federal Regulations (21 CFR 1040.30), the following notice applies to all lamps in the HID section of this catalog except E-Z Merc self ballasted lamps, High Pressure, Low Pressure Sodium Lamps, Saf-T-Gard® Multi-Vapor Lamps, CMH® MR16, CMH® PAR20 and CMH® PAR30.

**R WARNING: This lamp can cause serious skin burn and eye inflammation from shortwave ultraviolet radiation if outer envelope of the lamp is broken or punctured. Do not use where people will remain for more than a few minutes unless adequate shielding or other safety precautions are used. Lamps that will automatically extinguish when the outer envelope is broken or punctured are commercially available.**

# High Intensity Discharge Lamps

## Warning and Caution Notices

### 101 – Arcstream®

#### ⚠ WARNING

##### Risk of electric shock

- Turn power off before inspection, installation or removal
- Do not use where directly exposed to water or outdoors without an enclosed fixture

##### Risk of fire

- Keep combustible materials away from lamp
- Use in fixture rated for this product
- Use thermally protected ballast

##### A damaged lamp emits UV radiation which may cause eye/skin injury

- Turn power off if glass bulb is broken. Remove and dispose of lamp.

##### Unexpected lamp rupture may cause injury, fire, or property damage

- Do not exceed rated voltage
- Do not use where directly exposed to water or outdoors without an enclosed fixture
- Use in enclosed fixture rated for this product
- Do not use lamp if outer glass is scratched or broken
- Use only properly rated ballast
- Operate lamp only in specified position
- Turn lamp off at least once for 15 minutes per week
- Do not turn on lamp until fully installed

#### ⚠ CAUTION

##### Risk of burn

- Allow lamp to cool before handling
- Do not turn on lamp until fully installed

##### Lamp may shatter and cause injury if broken

- Wear safety glasses and gloves when handling lamp
- Do not use lamp if outer glass is scratched or broken
- Do not use excessive force when installing lamp

### 102 – Arcstream® G12 Kr85

#### ⚠ WARNING

##### Risk of electric shock

- Turn power off before inspection, installation or removal
- Do not use where directly exposed to water or outdoors without an enclosed fixture

##### Risk of fire

- Keep combustible materials away from lamp
- Use in fixture rated for this product
- Use thermally protected ballast

##### Lamp emits UV radiation which may cause eye/skin injury

- Avoid exposure of eyes and skin to unshielded lamp

##### Unexpected lamp rupture may cause injury, fire, or property damage

- Do not exceed rated voltage
- Do not touch glass with bare hands
- Do not use where directly exposed to water or outdoors without an enclosed fixture
- Use in enclosed fixture rated for this product
- Do not use lamp if outer glass is scratched or broken
- Use only properly rated ballast
- Turn lamp off at least once for 15 minutes per week
- Do not turn on lamp until fully installed

#### ⚠ CAUTION

##### Risk of burn

- Allow lamp to cool before handling
- Do not turn on lamp until fully installed

##### Lamp may shatter and cause injury if broken

- Do not use lamp if outer glass is scratched or broken
- Do not use excessive force when installing lamp

##### Notes

- ARC tube fill gas contains Kr85

### 103 – Arcstream® Rx7s Kr85

#### ⚠ WARNING

##### Risk of electric shock

- Turn power off before inspection, installation or removal
- Do not use where directly exposed to water or outdoors without an enclosed fixture

##### Risk of fire

- Keep combustible materials away from lamp
- Use in fixture rated for this product
- Use thermally protected ballast

##### A damaged lamp emits UV radiation which may cause eye/skin injury

- Turn power off if glass bulb is broken. Remove and dispose of lamp.

##### Unexpected lamp rupture may cause injury, fire, or property damage

- Do not exceed rated voltage
- Do not touch glass with bare hands
- Do not use in wet locations
- Use in enclosed fixture rated for this product
- Do not use lamp if outer glass is scratched or broken
- Use only properly rated ballast
- Operate lamp only in specified position
- Turn lamp off at least once for 15 minutes per week
- Do not turn on lamp until fully installed

#### ⚠ CAUTION

##### Risk of burn

- Allow lamp to cool before handling
- Do not turn on lamp until fully installed

##### Lamp may shatter and cause injury if broken

- Wear safety glasses and gloves when handling lamp
- Do not use lamp if outer glass is scratched or broken
- Dispose of lamp in a closed container
- Do not use excessive force when installing lamp

##### Notes

- ARC tube fill gas contains Kr85

### 104 – CMH® GU6.5, G12 and Mini Kr85

#### ⚠ WARNING

##### Risk of electric shock

- Turn power off before inspection, installation or removal
- Do not use where directly exposed to water or outdoors without an enclosed fixture

## Warning and Caution Notices (continued)

##### Risk of fire

- Keep combustible materials away from lamp
- Use in fixture rated for this product
- Use fused or thermally protected ballast—see instructions

##### A damaged lamp emits UV radiation which may cause eye/skin injury

- Turn power off if glass bulb is broken. Remove and dispose of lamp.

##### Unexpected lamp rupture may cause injury, fire, or property damage

- Do not exceed rated voltage
- Normal handling with bare hands is acceptable. Excessive handling of the quartz outer bulb should be avoided.
- Do not use where directly exposed to water or outdoors without an enclosed fixture

- Use in enclosed fixture rated for this product

- Do not use lamp if outer glass is scratched or broken

- Use only properly rated ballast

- Do not use beyond rated life

- Do not turn on lamp until fully installed

#### ⚠ CAUTION

##### Risk of burn

- Allow lamp to cool before handling
- Do not turn on lamp until fully installed

##### Lamp may shatter and cause injury if broken

- Do not use lamp if outer glass is scratched or broken
- Do not use excessive force when installing lamp

##### Notes

- ARC tube fill gas contains Kr85

- CMH® lamps may operate 24 hours a day/7 days a week to rated life—no shut off required

### 105 – CMH® HW HPS Kr85

#### ⚠ WARNING

##### Risk of electric shock

- Turn power off before inspection, installation or removal
- Do not use where directly exposed to water or outdoors without an enclosed fixture

##### Risk of fire

- Keep combustible materials away from lamp
- Use in fixture rated for this product
- Use electronic ballast, peak lead ballast, or system which can shut itself off if ballast overheating occurs. Does not apply to 250W CMH®

##### A damaged lamp emits UV radiation which may cause eye/skin injury

- Turn power off if glass bulb is broken. Remove and dispose of lamp.

##### Unexpected lamp rupture may cause injury, fire, or property damage

- Do not exceed rated voltage
- Do not use where directly exposed to water or outdoors without an enclosed fixture
- Use in enclosed luminaire with front cover made of GLASS, capable of containing the fragments of a lamp should it shatter, to avoid risk of fire. Do not use with polymeric lens.
- Do not use lamp if outer glass is scratched or broken
- Use only properly rated ballast
- Do not use beyond rated life
- Do not turn on lamp until fully installed

#### ⚠ CAUTION

##### Risk of burn

- Allow lamp to cool before handling
- Do not turn on lamp until fully installed

##### Lamp may shatter and cause injury if broken

- Wear safety glasses and gloves when handling lamp
- Do not use lamp if outer glass is scratched or broken
- Dispose of lamp in a closed container
- Do not use excessive force when installing lamp

##### Notes

- ARC tube fill gas contains Kr85
- CMH® lamps may operate 24 hours a day/7 days a week to rated life—no shut off required

### 106 – CMH® HW PA Kr85

#### ⚠ WARNING

##### Risk of electric shock

- Turn power off before inspection, installation or removal
- Do not use where directly exposed to water or outdoors without an enclosed fixture

##### Risk of fire

- Keep combustible materials away from lamp
- Use GE approved ballast/control gear

##### A damaged lamp emits UV radiation which may cause eye/skin injury

- Turn power off if glass bulb is broken. Remove and dispose of lamp.

##### Unexpected lamp rupture may cause injury, fire, or property damage

- Do not exceed rated voltage
- Do not use where directly exposed to water or outdoors without an enclosed fixture
- Do not use lamp if outer glass is scratched or broken
- Use only properly rated ballast
- Operate lamp only in specified position
- Do not store flammable materials near/below lamp
- Do not use beyond rated life
- Do not turn on lamp until fully installed

#### ⚠ CAUTION

##### Risk of burn

- Allow lamp to cool before handling
- Do not turn on lamp until fully installed

##### Lamp may shatter and cause injury if broken

- Do not use lamp if outer glass is scratched or broken
- Dispose of lamp in a closed container
- Do not use excessive force when installing lamp

##### Notes

- ARC tube fill gas contains Kr85
- CMH® lamps may operate 24 hours a day/7 days a week to rated life—no shut off required

### 107 – CMH® PAR 20-30 MR16 Kr85

#### ⚠ WARNING

##### Risk of electric shock

- Turn power off before inspection, installation or removal
- Do not use where directly exposed to water or outdoors without an enclosed fixture

# High Intensity Discharge Lamps

## Warning and Caution Notices (continued)

### Risk of fire

- Keep combustible materials away from lamp
- Use in fixture rated for this product
- Use fused or thermally protected ballast—see instructions

### Unexpected lamp rupture may cause injury, fire, or property damage

- Do not exceed rated voltage
- Do not use where directly exposed to water or outdoors without an enclosed fixture
- Do not use lamp if outer glass is scratched or broken
- Use only properly rated ballast
- Do not store flammable materials near/below lamp
- Do not use beyond rated life
- Do not turn on lamp until fully installed

### ⚠ CAUTION

### Risk of burn

- Allow lamp to cool before handling
- Do not turn on lamp until fully installed

### Lamp may shatter and cause injury if broken

- Do not use lamp if outer glass is scratched or broken
- Do not use excessive force when installing lamp

### Notes

- ARC tube fill gas contains Kr85
- CMH® lamps may operate 24 hours a day/7 days a week to rated life—no shut off required

## 108 – CMH® PAR38 Kr85

### ⚠ WARNING

### Risk of electric shock

- Turn power off before inspection, installation or removal
- Do not use where directly exposed to water or outdoors without an enclosed fixture

### Risk of fire

- Keep combustible materials away from lamp
- Use in fixture rated for this product

### A damaged lamp emits UV radiation which may cause eye/skin injury

- Turn power off if glass bulb is broken. Remove and dispose of lamp.

### Unexpected lamp rupture may cause injury, fire, or property damage

- Do not exceed rated voltage
- Do not use lamp if outer glass is scratched or broken
- Use only properly rated ballast
- Do not turn on lamp until fully installed

### ⚠ CAUTION

### Risk of burn

- Allow lamp to cool before handling
- Do not turn on lamp until fully installed

### Lamp may shatter and cause injury if broken

- Do not use lamp if outer glass is scratched or broken

### Notes

- ARC tube fill gas contains Kr85
- CMH® lamps may operate 24 hours a day/7 days a week to rated life—no shut off required

## 109 – CMH® TD Kr85

### ⚠ WARNING

### Risk of electric shock

- Turn power off before inspection, installation or removal
- Do not use where directly exposed to water or outdoors without an enclosed fixture

### Risk of fire

- Keep combustible materials away from lamp
- Use in fixture rated for this product

### A damaged lamp emits UV radiation which may cause eye/skin injury

- Turn power off if glass bulb is broken. Remove and dispose of lamp.

### Unexpected lamp rupture may cause injury, fire, or property damage

- Do not exceed rated voltage
- Normal handling with bare hands is acceptable. Excessive handling of the quartz outer bulb should be avoided.

- Do not use where directly exposed to water or outdoors without an enclosed fixture

- Use in enclosed fixture rated for this product

- Do not use lamp if outer glass is scratched or broken

- Use only properly rated ballast

- Operate lamp only in specified position

- Do not use beyond rated life

- Do not turn on lamp until fully installed

### ⚠ CAUTION

### Risk of burn

- Allow lamp to cool before handling
- Do not turn on lamp until fully installed

### Lamp may shatter and cause injury if broken

- Do not use lamp if outer glass is scratched or broken
- Do not use excessive force when installing lamp

### Notes

- ARC tube fill gas contains Kr85
- CMH® lamps may operate 24 hours a day/7 days a week to rated life—no shut off required

## 110 – Kolorarc® Kr85

### ⚠ WARNING

### Risk of electric shock

- Turn power off before inspection, installation or removal
- Do not use where directly exposed to water or outdoors without an enclosed fixture

### Risk of fire

- Keep combustible materials away from lamp
- Use in fixture rated for this product

### A damaged lamp emits UV radiation which may cause eye/skin injury

- Turn power off if glass bulb is broken. Remove and dispose of lamp.

### Unexpected lamp rupture may cause injury, fire, or property damage

- Do not exceed rated voltage
- Do not use where directly exposed to water or outdoors without an enclosed fixture

- Use in enclosed fixture rated for this product

- Do not use lamp if outer glass is scratched or broken

- Use only properly rated ballast

## Warning and Caution Notices (continued)

- Operate lamp only in specified position
- Turn lamp off at least once for 15 minutes per week
- Do not turn on lamp until fully installed

### ⚠ CAUTION

### Risk of burn

- Allow lamp to cool before handling
- Do not turn on lamp until fully installed

### Lamp may shatter and cause injury if broken

- Wear safety glasses and gloves when handling lamp
- Do not use lamp if outer glass is scratched or broken
- Dispose of lamp in a closed container
- Do not use excessive force when installing lamp

### Notes

- ARC tube fill gas contains Kr85

## 111 – Lucalox®

### ⚠ WARNING

### Risk of electric shock

- Turn power off before inspection, installation or removal
- Do not use where directly exposed to water or outdoors without an enclosed fixture

### Risk of fire

- Keep combustible materials away from lamp
- Use in fixture rated for this product

### Contains sodium—chemical burn risk

- Avoid skin contact with broken pieces

### Unexpected lamp rupture may cause injury, fire, or property damage

- Do not exceed rated voltage
- Do not use where directly exposed to water or outdoors without an enclosed fixture
- Do not use lamp if outer glass is scratched or broken
- Use only properly rated ballast
- Do not store flammable materials near/below lamp
- Do not turn on lamp until fully installed

### ⚠ CAUTION

### Risk of burn

- Allow lamp to cool before handling
- Do not turn on lamp until fully installed

### Lamp may shatter and cause injury if broken

- Wear safety glasses and gloves when handling lamp
- Do not use lamp if outer glass is scratched or broken
- Dispose of lamp in a closed container
- Do not use excessive force when installing lamp

## 112 – Lucalox® HO

### ⚠ WARNING

### Risk of electric shock

- Turn power off before inspection, installation or removal
- Do not use where directly exposed to water or outdoors without an enclosed fixture

### Risk of fire

- Keep combustible materials away from lamp
- Use in fixture rated for this product
- Use fused or thermally protected ballast—see instructions

### Contains sodium—chemical burn risk

- Avoid skin contact with broken pieces

### Unexpected lamp rupture may cause injury, fire, or property damage

- Do not exceed rated voltage
- Do not use where directly exposed to water or outdoors without an enclosed fixture
- Do not use lamp if outer glass is scratched or broken
- Use only properly rated ballast
- Do not store flammable materials near/below lamp
- Do not turn on lamp until fully installed

### ⚠ CAUTION

### Risk of burn

- Allow lamp to cool before handling
- Do not turn on lamp until fully installed

### Lamp may shatter and cause injury if broken

- Wear safety glasses and gloves when handling lamp
- Do not use lamp if outer glass is scratched or broken
- Dispose of lamp in a closed container
- Do not use excessive force when installing lamp

## 113 – Mercury

### ⚠ WARNING

### Risk of electric shock

- Turn power off before inspection, installation or removal
- Do not use where directly exposed to water or outdoors without an enclosed fixture

### Risk of fire

- Keep combustible materials away from lamp
- Use in fixture rated for this product

### A damaged lamp emits UV radiation which may cause eye/skin injury

- Turn power off if glass bulb is broken. Remove and dispose of lamp.

### Unexpected lamp rupture may cause injury, fire, or property damage

- Do not exceed rated voltage
- Do not use where directly exposed to water or outdoors without an enclosed fixture
- Do not use lamp if outer glass is scratched or broken
- Use only properly rated ballast
- Do not store flammable materials near/below lamp
- Do not use beyond rated life
- Do not turn on lamp until fully installed

### ⚠ CAUTION

### Risk of burn

- Allow lamp to cool before handling
- Do not turn on lamp until fully installed

### Lamp may shatter and cause injury if broken

- Do not use lamp if outer glass is scratched or broken
- Dispose of lamp in a closed container
- Do not use excessive force when installing lamp

### Notes

- ARC tube fill gas contains Kr85 (HR 1000 only)

# High Intensity Discharge Lamps

## Warning and Caution Notices (continued)

### 114 – Mercury Saf-T-Gard®

#### ⚠ WARNING

##### Risk of electric shock

- Turn power off before inspection, installation or removal
- Do not use where directly exposed to water or outdoors without an enclosed fixture

##### Risk of fire

- Keep combustible materials away from lamp
- Use in fixture rated for this product

##### Unexpected lamp rupture may cause injury, fire, or property damage

- Do not exceed rated voltage
- Do not use where directly exposed to water or outdoors without an enclosed fixture
- Do not use lamp if outer glass is scratched or broken
- Use only properly rated ballast
- Turn lamp off at least once for 15 minutes per week
- Do not store flammable materials near/below lamp
- Do not use beyond rated life
- Do not turn on lamp until fully installed

#### ⚠ CAUTION

##### Risk of burn

- Allow lamp to cool before handling
- Do not turn on lamp until fully installed

##### Lamp may shatter and cause injury if broken

- Do not use lamp if outer glass is scratched or broken
- Dispose of lamp in a closed container
- Do not use excessive force when installing lamp

### 115 – Mercury Self-Ballasted

#### ⚠ WARNING

##### Risk of electric shock

- Turn power off before inspection, installation or removal
- Do not use where directly exposed to water or outdoors without an enclosed fixture

##### Risk of fire

- Keep combustible materials away from lamp
- Use in fixture rated for this product

##### A damaged lamp emits UV radiation which may cause eye/skin injury

- Turn power off if glass bulb is broken. Remove and dispose of lamp.

##### Unexpected lamp rupture may cause injury, fire, or property damage

- Do not exceed rated voltage
- Do not use where directly exposed to water or outdoors without an enclosed fixture
- Do not use lamp if outer glass is scratched or broken

#### ⚠ CAUTION

##### Risk of burn

- Allow lamp to cool before handling
- Do not turn on lamp until fully installed

##### Lamp may shatter and cause injury if broken

- Do not use lamp if outer glass is scratched or broken
- Dispose of lamp in a closed container
- Do not use excessive force when installing lamp

### 116 – QMH E-rated Kr85 and CMH®

#### ⚠ WARNING

##### Risk of electric shock

- Turn power off before inspection, installation or removal
- Do not use where directly exposed to water or outdoors without an enclosed fixture

##### Risk of fire

- Keep combustible materials away from lamp
- Use in fixture rated for this product

##### A damaged lamp emits UV radiation which may cause eye/skin injury

- Turn power off if glass bulb is broken. Remove and dispose of lamp.

##### Unexpected lamp rupture may cause injury, fire, or property damage

- Do not exceed rated voltage
- Do not use where directly exposed to water or outdoors without an enclosed fixture
- Use in enclosed fixture rated for this product
- Do not use lamp if outer glass is scratched or broken
- Use only properly rated ballast
- Operate lamp only in specified position
- Turn lamp off at least once for 15 minutes per week. Does not apply to CMH®
- Do not use beyond rated life
- If used on a dimming system, see instructions
- Do not turn on lamp until fully installed

#### ⚠ CAUTION

##### Risk of burn

- Allow lamp to cool before handling
- Do not turn on lamp until fully installed

##### Lamp may shatter and cause injury if broken

- Do not use lamp if outer glass is scratched or broken
- Dispose of lamp in a closed container
- Do not use excessive force when installing lamp

##### Notes

- ARC tube fill gas contains Kr85
- CMH® lamps may operate 24 hours a day/7 days a week to rated life—no shut off required

### 117 – QMH HOR Enclosed Kr85

#### ⚠ WARNING

##### Risk of electric shock

- Turn power off before inspection, installation or removal
- Do not use where directly exposed to water or outdoors without an enclosed fixture

##### Risk of fire

- Keep combustible materials away from lamp
- Use in fixture rated for this product

##### A damaged lamp emits UV radiation which may cause eye/skin injury

- Turn power off if glass bulb is broken. Remove and dispose of lamp.

##### Unexpected lamp rupture may cause injury, fire, or property damage

- Do not exceed rated voltage
- Do not use where directly exposed to water or outdoors without an enclosed fixture
- Use in enclosed fixture rated for this product

## Warning and Caution Notices (continued)

- Do not use lamp if outer glass is scratched or broken
- Use only properly rated ballast
- Operate lamp only in specified position
- Turn lamp off at least once for 15 minutes per week
- Do not use beyond rated life
- Do not remove base locating pin if so equipped
- Do not turn on lamp until fully installed

#### ⚠ CAUTION

##### Risk of burn

- Allow lamp to cool before handling
- Do not turn on lamp until fully installed

##### Lamp may shatter and cause injury if broken

- Do not use lamp if outer glass is scratched or broken
- Dispose of lamp in a closed container
- Do not use excessive force when installing lamp

##### Notes

- ARC tube fill gas contains Kr85

### 118 – QMH LW Kr85

#### ⚠ WARNING

##### Risk of electric shock

- Turn power off before inspection, installation or removal
- Do not use where directly exposed to water or outdoors without an enclosed fixture

##### Risk of fire

- Keep combustible materials away from lamp
- Use in fixture rated for this product

##### A damaged lamp emits UV radiation which may cause eye/skin injury

- Turn power off if glass bulb is broken. Remove and dispose of lamp.

##### Unexpected lamp rupture may cause injury, fire, or property damage

- Do not exceed rated voltage
- Do not use where directly exposed to water or outdoors without an enclosed fixture
- Use in enclosed fixture rated for this product
- Do not use lamp if outer glass is scratched or broken
- Use only properly rated ballast
- Turn lamp off at least once for 15 minutes per week
- Do not use beyond rated life
- Do not turn on lamp until fully installed

#### ⚠ CAUTION

##### Risk of burn

- Allow lamp to cool before handling
- Do not turn on lamp until fully installed

##### Lamp may shatter and cause injury if broken

- Do not use lamp if outer glass is scratched or broken
- Dispose of lamp in a closed container
- Do not use excessive force when installing lamp

##### Notes

- ARC tube fill gas contains Kr85

### 119 – QMH Protected

#### ⚠ WARNING

##### Risk of electric shock

- Turn power off before inspection, installation or removal
- Do not use where directly exposed to water or outdoors without an enclosed fixture

##### Risk of fire

- Keep combustible materials away from lamp
- Use in fixture rated for this product

##### A damaged lamp emits UV radiation which may cause eye/skin injury

- Turn power off if glass bulb is broken. Remove and dispose of lamp.

##### Unexpected lamp rupture may cause injury, fire, or property damage

- Do not exceed rated voltage
- Do not use where directly exposed to water or outdoors without an enclosed fixture
- Do not use lamp if outer glass is scratched or broken
- Use only properly rated ballast
- Operate lamp only in specified position
- Turn lamp off at least once for 15 minutes per week
- Do not store flammable materials near/below lamp
- Do not use beyond rated life
- If used on a dimming system, see instructions.
- Do not turn on lamp until fully installed

#### ⚠ CAUTION

##### Risk of burn

- Allow lamp to cool before handling
- Do not turn on lamp until fully installed

##### Lamp may shatter and cause injury if broken

- Do not use lamp if outer glass is scratched or broken
- Dispose of lamp in a closed container
- Do not use excessive force when installing lamp

### 120 – QMH Protected Kr85

#### ⚠ WARNING

##### Risk of electric shock

- Turn power off before inspection, installation or removal
- Do not use where directly exposed to water or outdoors without an enclosed fixture

##### Risk of fire

- Keep combustible materials away from lamp
- Use in fixture rated for this product

##### A damaged lamp emits UV radiation which may cause eye/skin injury

- Turn power off if glass bulb is broken. Remove and dispose of lamp.

##### Unexpected lamp rupture may cause injury, fire, or property damage

- Do not exceed rated voltage
- Do not use where directly exposed to water or outdoors without an enclosed fixture
- Do not use lamp if outer glass is scratched or broken
- Use only properly rated ballast
- Operate lamp only in specified position
- Turn lamp off at least once for 15 minutes per week
- Do not store flammable materials near/below lamp
- Do not use beyond rated life
- Do not turn on lamp until fully installed

# High Intensity Discharge Lamps

## Warning and Caution Notices (continued)

### ⚠ CAUTION

#### Risk of burn

- Allow lamp to cool before handling
- Do not turn on lamp until fully installed

#### Lamp may shatter and cause injury if broken

- Do not use lamp if outer glass is scratched or broken
- Dispose of lamp in a closed container
- Do not use excessive force when installing lamp

#### Notes

- ARC tube fill gas contains Kr85

### 121 – QMH S-rated

### ⚠ WARNING

#### Risk of electric shock

- Turn power off before inspection, installation or removal
- Do not use where directly exposed to water or outdoors without an enclosed fixture

#### Risk of fire

- Keep combustible materials away from lamp
- Use in fixture rated for this product

#### A damaged lamp emits UV radiation which may cause eye/skin injury

- Turn power off if glass bulb is broken. Remove and dispose of lamp.

#### Unexpected lamp rupture may cause injury, fire, or property damage

- Do not exceed rated voltage
- Do not use where directly exposed to water or outdoors without an enclosed fixture
- Use in enclosed fixture rated for this product—see instructions
- Do not use lamp if outer glass is scratched or broken
- Use only properly rated ballast
- Operate lamp only in specified position
- Turn lamp off at least once for 15 minutes per week
- Do not store flammable materials near/below lamp
- Do not use beyond rated life
- If used on a dimming system, see instructions
- Do not turn on lamp until fully installed

### ⚠ CAUTION

#### Risk of burn

- Allow lamp to cool before handling
- Do not turn on lamp until fully installed

#### Lamp may shatter and cause injury if broken

- Wear safety glasses and gloves when handling lamp
- Do not use lamp if outer glass is scratched or broken
- Dispose of lamp in a closed container
- Do not use excessive force when installing lamp

### 122 – QMH S-rated Kr85

### ⚠ WARNING

#### Risk of electric shock

- Turn power off before inspection, installation or removal
- Do not use where directly exposed to water or outdoors without an enclosed fixture

#### Risk of fire

- Keep combustible materials away from lamp
- Use in fixture rated for this product

#### A damaged lamp emits UV radiation which may cause eye/skin injury

- Turn power off if glass bulb is broken. Remove and dispose of lamp.

#### Unexpected lamp rupture may cause injury, fire, or property damage

- Do not exceed rated voltage
- Do not use where directly exposed to water or outdoors without an enclosed fixture
- Use in enclosed fixture rated for this product—see instructions
- Do not use lamp if outer glass is scratched or broken
- Use only properly rated ballast
- Operate lamp only in specified position
- Turn lamp off at least once for 15 minutes per week
- Do not store flammable materials near/below lamp
- Do not use beyond rated life
- If used on a dimming system, see instructions
- Do not turn on lamp until fully installed

### ⚠ CAUTION

#### Risk of burn

- Allow lamp to cool before handling
- Do not turn on lamp until fully installed

#### Lamp may shatter and cause injury if broken

- Do not use lamp if outer glass is scratched or broken
- Dispose of lamp in a closed container
- Do not use excessive force when installing lamp

#### Notes

- ARC tube fill gas contains Kr85

### 123 – QMH S-rated Saf-T-Gard®

### ⚠ WARNING

#### Risk of electric shock

- Turn power off before inspection, installation or removal
- Do not use where directly exposed to water or outdoors without an enclosed fixture

#### Risk of fire

- Keep combustible materials away from lamp
- Use in fixture rated for this product

#### Unexpected lamp rupture may cause injury, fire, or property damage

- Do not exceed rated voltage
- Do not use where directly exposed to water or outdoors without an enclosed fixture
- Use in enclosed fixture rated for this product—see instructions
- Do not use lamp if outer glass is scratched or broken
- Use only properly rated ballast
- Operate lamp only in specified position
- Turn lamp off at least once for 15 minutes per week
- Do not store flammable materials near/below lamp
- Do not use beyond rated life
- Do not turn on lamp until fully installed

## Warning and Caution Notices (continued)

### ⚠ CAUTION

#### Risk of burn

- Allow lamp to cool before handling
- Do not turn on lamp until fully installed

#### Lamp may shatter and cause injury if broken

- Do not use lamp if outer glass is scratched or broken
- Dispose of lamp in a closed container
- Do not use excessive force when installing lamp

### 124 – Sport 1000W PAR64

### ⚠ WARNING

#### Risk of electric shock

- Turn power off before inspection, installation or removal
- Do not use where directly exposed to water or outdoors without an enclosed fixture

#### Risk of fire

- Keep combustible materials away from lamp
- Use in fixture rated for this product

#### A damaged lamp emits UV radiation which may cause eye/skin injury

- Turn power off if glass bulb is broken. Remove and dispose of lamp.

#### Unexpected lamp rupture may cause injury, fire, or property damage

- Do not exceed rated voltage
- Do not use where directly exposed to water or outdoors without an enclosed fixture
- Use in enclosed fixture rated for this product
- Do not use lamp if outer glass is scratched or broken
- Use only properly rated ballast
- Operate lamp only in specified position
- Turn lamp off at least once for 15 minutes per week
- Do not turn on lamp until fully installed

### ⚠ CAUTION

#### Risk of burn

- Allow lamp to cool before handling
- Do not turn on lamp until fully installed

#### Lamp may shatter and cause injury if broken

- Wear safety glasses and gloves when handling lamp
- Do not use lamp if outer glass is scratched or broken
- Dispose of lamp in a closed container
- Do not use excessive force when installing lamp

### 125 – Sport MBIL-CSI-CID

### ⚠ WARNING

#### Risk of electric shock

- Turn power off before inspection, installation or removal
- Do not use where directly exposed to water or outdoors without an enclosed fixture

#### Risk of fire

- Keep combustible materials away from lamp
- Use in fixture rated for this product

#### Lamp emits UV radiation which may cause eye/skin injury

- Avoid exposure of eyes and skin to unshielded lamp

#### Unexpected lamp rupture may cause injury, fire, or property damage

- Do not exceed rated voltage
- Do not touch glass with bare hands
- Do not use where directly exposed to water or outdoors without an enclosed fixture
- Use in enclosed fixture rated for this product
- Do not use lamp if outer glass is scratched or broken
- Use only properly rated ballast
- Operate lamp only in specified position
- Turn lamp off at least once for 15 minutes per week
- Do not turn on lamp until fully installed

### ⚠ CAUTION

#### Risk of burn

- Allow lamp to cool before handling
- Do not turn on lamp until fully installed

#### Lamp may shatter and cause injury if broken

- Do not use lamp if outer glass is scratched or broken
- Do not use excessive force when installing lamp

# High Intensity Discharge Lamps

## Cross-Reference

GE Description	Osram/ Sylvania Description	Philips Description
Order This GE Lamp	If you currently use these lamps	
<b>Standard &amp; Ecolux® HPS Lamps</b>		
<b>Lucalox®</b>	<b>Lumalux®</b>	<b>Ceramalux™</b>
LU35/MED	LU35/MED	C35S76/M
LU35/D/MED	LU35/D/MED	C35S76/D/M
LU50/MED/ECO	LU50/MED	C50S68/M
LU50/D/MED/ECO	LU50/D/MED	C50S68/M
LU50/H/ECO	LU50/ECO	C50S68/ALTO
LU50/D/H/ECO	LU50/D	C50S68/D
LU70/MED/ECO	LU70/MED	C70S62/M
LU70/D/MED/ECO	LU70/D/MED	C70S62/D/M
LU70/ECO/H/ECO	LU70/ECO	C70S62/ALTO
LU70/ECO/NC	LU70/PLUS/ECO	—
LU70/D/H/ECO	LU70/D	C70S62/D
LU100/MED/ECO	LU100/MED	C100S54/M
LU100/D/MED/ECO	LU100/D/MED	C100S54/D/M
LU100/H/ECO	LU100/ECO	C100S54/ALTO
LU100/ECO/NC	LU100/PLUS/ECO	—
LU100/D/H/ECO	LU100/D	C100S54/D
LU150/MED/ECO	LU150/55/MED	CC150S55/M
LU150/D/MED/ECO	LU150/55/D/MED	C150S55/D/M
LU150/55/H/ECO	LU150/55/ECO	C150S55/ALTO
LU150/ECO/NC	LU150/55/PLUS/ECO	—
LU150/55/D/H/ECO	LU150/55/D	C150S55/D
LU150/100/H/ECO	LU150/100	C150S56/ALTO
LU200/H/ECO	LU200/ECO	C200S66
LU200/ECO/NC	LU200/PLUS/ECO	—
LU250/H/ECO	LU250/ECO	C250S50
LU250/ECO/NC	LU250/PLUS/ECO	—
LU250/D/H/ECO	LU250/D	C250S50/D
LU310	LU310/ECO	C310S67
LU400/H/ECO	LU400/ECO	C400S51
LU400/ECO/NC	LU400/PLUS/ECO	—
LU400/D	LU400/D	C400S51/D
LU750	LU750	—
LU1000/ECO	LU1000	C1000S52
<b>Deluxe High Pressure Sodium Lamps</b>		
<b>Lucalox®</b>	<b>Lumalux®</b>	<b>Ceramalux™</b>
LU70/DX/MED	—	C70S62/C/M
LU150/DX/MED	—	C150S55/C/M
LU150/55/DX	—	C150S55/C
LU250/DX	—	C250S50/C
LU400/DX	—	C400S51/C
<b>Standby Longlife High Pressure Sodium Lamps</b>		
<b>Lucalox®</b>	<b>Lumalux®</b>	<b>Ceramalux™</b>
LU70/SBY/XL	LU70/SBY	C70S62/2
LU100/SBY/XL	LU100/SBY	C100S54/2
LU150/55/SBY/XL	LU150/55/SBY	C150S55/2
LU200/SBY/XL	LU200/100/SBY	—
LU250/SBY/XL	LU250/SBY	C250S50/2
LU400/SBY/XL	LU400/SBY	C400S51/2
LU1000/SBY/XL	LU1000/SBY	C1000S52/2
<b>EZ-LUX® High Pressure Sodium Lamps</b>		
<b>E-Z LUX®</b>	<b>Unalux®</b>	<b>Ceramalux™</b>
LUH150/EZ	ULX150	C150S63 RETROLUX
LUH215/EZ	ULX215	C215S675 RETROLUX
LUH360/EZ	ULX360	C360S64 RETROLUX
<b>Ceramic Metal Halide Lamps</b>		
<b>CMH®</b>	<b>Powerball®</b>	<b>MasterColor®</b>
CMH20/MR16/830/SP	—	—
CMH20/MR16/830/FL	—	—
CMH20/MR16/830/WFL	—	—
CMH39MR16/930/SP	—	—
CMH39MR16/930/FL	—	—

GE Description	Osram/ Sylvania Description	Philips Description
Order This GE Lamp	If you currently use these lamps	
<b>Ceramic Metal Halide Lamps (continued)</b>		
<b>CMH®</b>	<b>Powerball®</b>	<b>MasterColor®</b>
CMH39MR16/930/WFL	—	—
CMH39MR16/942/SP	—	—
CMH39MR16/942/FL	—	—
CMH39MR16/942/WFL	—	—
CMH20/PAR20/SP	—	—
CMH20/PAR20/FL	—	—
CMH20/PAR30/SP10	MCP20PAR30LN/U/830/SP	—
CMH20/PAR30/SP15	—	—
CMH20/PAR30/FL25	MCP20PAR30LN/U/830/FL	CDM20/PAR30/L/MFL/3K
CMH39/PAR20/830/SP10	MCP39PAR20/U/830/SP	CDM35/PAR20/M/SP3K
CMH39/PAR20/830/FL30	MCP39PAR20/U/830/FL	CDM35/PAR20/M/FL3K
CMH39/PAR20/NSP4K	—	CDM35/PAR20/M/SP4K
CMH39/PAR20/FL4K	—	CDM35/PAR20/M/FL4K
CMH39/PAR30L/830/SP10	MCP39PAR30LN/U/830/SP	CDM35/PAR30L/M/SP
CMH39/PAR30L/830/SP15	—	—
CMH39/PAR30L/830/FL25	MCP39PAR30LN/U/830/FL	CDM35/PAR30L/M/FL
CMH39/PAR30LNS4PK	—	—
CMH39/PAR30L/SP4K	—	—
CMH39/PAR30L/FL4K	—	—
CMH70/PAR30L/830/SP15	MCP70PAR30LN/U/830/SP	CDM70/PAR30L/M/SP
CMH70/PAR30L/830/FL40	MCP70PAR30LN/U/830/FL	CDM70/PAR30L/M/FL
CMH70/PAR38/830/SP15	MCP70PAR38/U/830/SP	CDM70/PAR38/SP3K
CMH70/PAR38/830/FL25	MCP70PAR38/U/830/FL	CDM70/PAR38/FL3K
CMH70/PAR38/830/WFL	MCP70PAR38/U/830/WFL	CDM70/PAR38/WFL3K
CMH100/PAR38/830/SP15	MCP100PAR38/U/830/SP	CDM100/PAR38/SP3K
CMH100/PAR38/830/FL25	MCP100PAR38/U/830/FL	CDM100/PAR38/FL3K
CMH100/PAR38/830/WFL	MCP100PAR38/U/830/WFL	CDM100/PAR38/WFL3K
CMH70/C/U/830/MED	MCP70/C/U/MED/830	MHC70/U/M/3K
CMH70/C/U/830/MED	MCP70/C/U/MED/830	MHC70/C/U/M/3K
CMH100/U/830/MED	MCP100/C/U/MED/830	MHC100/U/M/3K
CMH100/C/U/830/MED	MCP100/C/U/MED/830	MHC100/C/U/M/3K
CMH70/U/830/MED/O	MCP70/U/MED/830	MHC70/U/MP/3K/ALTO
CMH70/C/U/830/MED/O	MCP70/C/U/MED/830	MHC70/C/U/MP/3K/ALTO
CMH70/U/942/MED/O	MCP70/U/MED/940	MHC70/U/MP/4K/ALTO
CMH70/C/U/942/MED/O	MCP70/C/U/MED/940	MHC70/C/U/MP/4K/ALTO
CMH150/U/830/MED/O	MCP150/U/MED/830	MCH150/U/MP/3K/ALTO
CMH150/C/U/830/MED/O	MCP150/C/U/MED/830	MHC150/C/U/MP/3K/ALTO
CMH150/U/942/MED/O	—	MHC150/U/MP/4K/ALTO
CMH150/C/U/942/MED/O	—	MHC150/C/U/MP/4K/ALTO
CMH20/T/U/830/G12	—	—
CMH39/T/U/830/G12	MC39T6/U/G12/830	CDM35/T6/830
CMH39/TC/U/942/G12	MC39T6/U/G12/940	CDM35/T6/842
CMH70/T/U/830/G12	MC70T6/U/G12/830	CDM70/T6/830
CMH70/T/U/942/G12	MC70T6/U/G12/940	CDM70/T6/942
CMH150/T/U/830/G12	MC150T6/U/G12/830	CDM150/T6/830
CMH150/T/U/942/G12	MC150T6/U/G12/940	CDM150/T6/942
CMH70/TD/830/Rx7s	MC70T6/DE/830	CDM70/TD/830
CMH70/TD/942/Rx7s	—	CDM70/TD/942
CMH150/TD/830/Rx7s	MC150T6/DE/830	CDM150/TD/830
CMH150/TD/942/Rx7s	—	CDM150/TD/942
CMH250/V/PA/O	MCP250/PS/BU only	CDM250/V/O/PS/4K
CMH250C/V/PA/O	MCP250/C/PS/BU only	CDM250/C/V/O/PS/4K
CMH320/V/PA/O	MCP320/PS/BU only	CDM320/V/O/PS/4K
CMH320C/V/PA/O	MCP320/C/PS BU only	CDM320/C/V/O/PS/4K
CMH350/V/PA/O	—	CDM350/V/O/PS/4K
CMH350C/V/PA/O	—	CDM350/C/V/O/PS/4K
CMH400/V/PA/O	—	CDM400/V/O/PS/4K
CMH400C/V/PA/O	—	CDM400/C/V/O/PS/4K
CMH20/TC/U/830/GU6.5	—	—
CMH39T/U930GU6.5	—	—
CMH39T/U942GU6.5	—	—
CMH39T/U942GU6.5	—	—
CMH20/TC/U/830/G8.5	MC20TC/U/G8.5/830	—

## Cross-Reference (continued)

GE Description	Osram/ Sylvania Description	Philips Description
Order This GE Lamp	If you currently use these lamps	
<b>Ceramic Metal Halide Lamps (continued)</b>		
<b>CMH®</b>	<b>Powerball®</b>	<b>MasterColor®</b>
CMH39/TC/U/830/G8.5	MC39TC/U/G8.5/830	CDM35/TC/830
CMH39/TC/U/942/G8.5	MC39TC/U/G8.5/942	CDM35/TC/942
CMH70/TC/U/830/G8.5	MC70TC/U/G8.5/830	CDM70/TC/830
CMH70/TC/U/942/G8.5	MC70TC/U/G8.5/942	CDM70/TC/942
CMH250/U/830/R	—	CDM250S50/V/O/4K
CMH400/U/830/R	—	CDM400S51/V/O/4K
<b>Multi-Vapor® PulseArc® Metal Halide Lamps</b>		
<b>PulseArc®</b>	<b>MetalArc®</b>	
MXR32C/VBU	—	—
MXR50/U/MED	MP50/U/MED	MH50/U/M
MXR50/C/U/MED	MP50/C/U/MED	MH50/C/U/M
MXR70/U/MED	MH70/U/MED	MHC70/U/M/3K
MXR70/C/U/MED	MH70/C/U/MED	MHC70/C/U/M/3K
MXR70/U/MED/O	MP70/U/MED	MHC70/C/U/M/3K
MXR70/C/U/MED/O	MP70/C/U/MED	MHC70/C/U/M/3K
MXR100/U/MED	M100/U/MRD	MHC100/U/M/3K
MXR100/C/U/MED	MH100/C/U/MED	MHC100/C/U/M/3K
MVR100/U/MED	MH100/U/4K/MED	MHC100/U/M/4K
MVR100/C/U/MED	—	MHC100/C/U/M/4K
MXR100/U/MED/O	MP100/U/MED	MHC100/U/M/3K
MXR100/C/U/MED/O	MP100/C/U/MED	MHC100/C/U/M/3K
MXR150/U/MED	M150/U/MED	MH150/U/M
MXR150/C/U/MED	M150/C/U/MED	MH150/C/U/M
MVR175/VBU/PA	MS175/PS/BU	MS175/BU/PS
MVR175/C/VBU/PA	MS175/C/PS/BU	—
MVR250/VBU/PA	MS250/PS/BU	MS250/BU/PS
MVR250/C/VBU/PA	MS250/C/PS/BU	—
MVR250/HOR/PA	M250/PS/U	—
MVR320/VBU/HO/PA	MS320/PS/BU	MS320/BU/PS
MVR320/C/VBU/HO/PA	MS320/C/PS/BU-HOR	MS320/C/BU/PS
MVR320/VBU/XHO/PA	MP320/350/PS/BU	MP320/BU/PS
MVR320/C/VBU/XHO/PA	MP320/350/C/PS/BU	MP320/C/BU/PS
MVR320/HOR/PA	M320/PS/BU-HOR	MS320/PS/U
MVR350/VBU/PA	MP350/350/PS/BU	MP350/BU/PS
MVR350/C/VBU/PA	MP350/350/C/PS/BU	MP350/C/BU/PS
MVR400/VBU/XHO/PA	MP350/400/PS/BU	MP400/BU/PS
MVR400/C/VBU/XHO/PA	MP350/400/C/PS/BU	MP400/C/BU/PS
MVR400/HOR/PA	M400/PS/U	MS400/HOR/PS
MVR400/HOR/ED28/PA	M400/PS/U/ED28	—
MVR750/VBU/PA	MS750/PS/BU-HOR/ED28	—
MVR750/C/VBU/PA	MS750/C/PS/BU-HOR/ED28	—
MVR1000/ED28/PA	M1000/PS/U/ED28	MS1000/BU/ED28/PS
<b>Multi-Vapor® Standard Metal Halide Lamps</b>		
<b>Multi-Vapor®</b>	<b>MetalArc®</b>	
MVR175/U/MED	M175/U/MED	MH175/U/M
MVR175/C/U/MED	M175/C/U/MED	MH175/C/U/M
MVR175/U	M175/U	MH175/U
MVR175/C/U	M175/C/U	MH175/C/U
MVR175/HOR	MS175/HOR	MS175/HOR
MVR175/C/HOR	MS175/C/HOR	MS175/C/HOR
MVR250/U	M250/U	MH250/U
MVR250/C/U	M250/C/U	MH250/C/U
MVR250/SP30/U	M2503K/BU-only	MH250/3K/BU
MVR250/HOR	MS250/HOR	MS250/HOR
MVR250/C/HOR	MS250/C/HOR	MS250/C/HOR
MVR400/U	M400/U	MH400/U
MVR400/C/U	M400/C/U	MH400/C/U
MVR400/SP30/U	MS400/BU	MH400/3K/U
MVR400/VBU	MS400/BU	MS400/BU
MVR400/VBD	MS400/BD	—
MVR400/C/VBU	MS400/C/BU	MS400/C/BU&

GE Description	Osram/ Sylvania Description	Philips Description
Order This GE Lamp	If you currently use these lamps	
<b>Multi-Vapor® Standard Metal Halide Lamps (continued)</b>		
<b>Multi-Vapor®</b>	<b>MetalArc®</b>	
MVR400/C/VBD	MS400/C/BD	—
MVR400/HOR	MS400/HOR	MS400/HOR
MVR400/C/HOR	MS400/C/HOR	MS400/C/HOR
MVR400/SP30/HOR	MS400/3K/HOR	—
MVR400/U	MP400/BU	MP400/U
MVR400/VBU	MP400/BU/BD	—
MVR1000/U	M1000/U	MH1000/U
MVR1000/C/U	M1000/C/U	MH1000/C/U
MVR1000/VBU	MS1000/BU	MS1000/BU
MVR1000/VBU/O	MP1000/BU	MP1000/BU
MVR1500/U/SPORTS	M1500/BU-HOR	MH1500BU
MVR250/HOR/PA	MS250/PS/U	—
MVR320/HOR/PA	MS320/PS/BV-HOR	MS320/PS/U
MVR400/HOR/ED28/PA	M400/PS/U/ED28	—
<b>Double-Ended Lamps</b>		
<b>PulseArc®</b>	<b>MetalArc®</b>	
ARC70/TD/730/R7S	HQI-DE70/WDX	CDM70/TD/830
ARC70/TD/743/R7S	—	MHN70/TD/840
ARC150/TD/730/R7S	HQI-DE150/WDX	CDM150/TD/830
ARC150/TD/742/R7S	HQI-DE150/NDX	MHN150/TD/840
<b>Safety Metal Halide Lamps</b>		
MVT400/VBU	MPT400/BU	MHT400/U
MVT400/C/VBU	MPT400/C/BU	MHT400/C/U
<b>Mercury Vapor Lamps</b>		
HR40/50DX45-46	H45/46DL-40/50/DX	H46DL-40-50/DX
HR75DX43	H43AV-75/DX	H43AV-75/DX
HR100A38/A23	—	—
HR100DX38/A23	H38AV-100/DX	H38MP-100/DX
HR100A38	H38HT-100	H38HT-100
HR100DX38	H38JA-100/DX	H38JA-100/DX
HR100WDX38	H38JA-100/N	—
HR100RFL38	—	—
HR100RDXFL38	H38BP-100/DX	H38BP-100/DX
HR175A39	H39KB-175	H39KB-175
HR175DX39	H39KC-175/DX	H39KC-175/DX
HT175DX39	H39KC-T175/DX	H39KC-T175
HR175WDX39	H39KC-175/N	—
HR175RFL39	—	H39BM-175
HR175RDXFL39	H39BP-175/DX	H39BP-175/DX
HR250A37	H37KB-250	H37KB-250
HR250DX37	H37KC-250/DX	H37KC-250/DX
HR400A33	H33CD-400	H33CD-400
HR400DX33	H33GL-400/DX	H33GL-400/DX
HR400DX33BT	—	—
HT400DX33	H33GL-T400/DX	H33GL-T400/DX
HR400WDX33	H33GL-400/N	—
HR400RDX33	—	H33DN-400/DX
HR400RDXFL33	—	H33FS-400/DX
HR1000DX34	H34GW-1000/DX	H34GW-1000/DX
HR1000A36	H36GV-1000	H36GV-1000
HR1000DX36	H36GW-1000/DX	H36GW-1000/DX
<b>Self-Ballasted Mercury Vapor Lamps</b>		
<b>E-Z MERC®</b>		
HSB160/M	—	—
HSB250	—	

